

Deep Freezers
Water Baths
Shaking Water Baths
Incubators
Shakers
Water Stills

GFL[®]



www.GFL.de



Summary of Laboratory Products



■ Chest Freezers Page 3



■ Upright Freezers Page 3

■ Water Baths Page 21

■ Tissue Float Bath Page 31



■ Shaking Water Baths Page 33

■ THERMOLAB® Page 38

■ Incubators Page 41



■ Shaking Incubators Page 44

■ Hybridisation Incubator Page 48



■ Mini Incubator Page 50

■ Tube Roller Incubator Page 50



■ Shakers Page 53

■ Test Tube Rotator Page 64



■ Rotating Shaker Page 65

■ Water Stills Page 71



Would you like to find out more details about our range of products?

Phone: ++ 49 - 5139 99 58 - 0

Fax: ++ 49 - 5139 99 58 21

E-Mail: info@GFL.de

Internet: www.GFL.de

Deep Freezers

GFL[®]



- Chest and Upright Freezers up to -85°C for long-term storage and quality assurance



Quality built on Tradition

Users in research labs, standard and special labs for medicine, science and industry throughout the world have been profiting from the precision and dependability of our products for 45 years, all of which comply with valid European standards and bear the CE mark.

In the future, the success of a product spectrum of laboratory devices that meet the toughest demands on material, functioning and design will continue to be ensured by experience of every-day use in detail, ongoing technical advances and an excellent quality approach.

The phrase „Quality built on Tradition“ encompasses more than just the sum of impressive product innovations. It is also an expression of our corporate policy, which includes a high degree of ready-and-waiting service as our primary customer-friendly service goal.

This applies to all of the GFL laboratory products that are produced exclusively at our plant in Germany - Shakers, Shaking Water Baths, Water Baths, Incubators or Water Stills, Deep Freezers alike.



Secure future

A vested quality demand in accordance with international standards is documented for all GFL laboratory products with the certification to DIN EN ISO 9001:2008, promoting more trust in the permanent high quality level of our products.

In addition to the continuous optimisation of ongoing production processes, the ISO obligation also calls for the commitment to quality awareness of our employees and the continuous development and rapid implementation of preventive measures to ensure quality assurance at a high level.

GFL Unit Control by PC



GFL Deep Freezers are equipped with both microprocessor technique and an interface module for convenient remote control, monitoring and temperature recording via PC.

Trouble-free data transfer is realised via the built-in serial RS 232 port. Also available are two further data transfer formats, RS 422 and RS 485, making the units compatible,

for example, to the PC software labworldsoft®.

This software enables the user, among other things, to control via PC up to 64 lab devices independently from one another and to evaluate all data. Output signals of specified and actual values are available.

Data acquisition is effected online and can be presented either graphically or numerically. Complete measuring

configurations can be stored with all of their current parameters for optimum reproducibility.

System requirements:

Hardware

- Pentium 90 with at least 16 MB RAM, 8 MB free HDD space, mouse
- VGA display; monochrome display with at least 16 grey levels, or colour

Software

- Windows 95/98/2000/NT/ME/XP...

Contents

Page

GFL Deep Freezers	6-7
Upright and Chest Freezers	8-11
Special makes	12-13
Accessories	14-15
Storage system	16-17
Technical data	18-20



Deep Freezers from GFL - enjoying success



6485 Upright Freezer,
500 litres, with storage system
and three additional shelves

The GFL Deep Freezer programme includes Chest and Upright Freezers with capacities ranging from 30 to 500 litres volume. There are 12 Chest Freezers with six different volumes, respectively, six Upright Freezers having three different storage volumes.

Both of these product groups are designed for temperatures of 0 °C to -40 °C, or -50 °C to -85 °C in an ambient temperature of up to +28 °C.

- Organic substances which must be stored for extended periods normally represent invaluable assets. Preservation of these substances therefore requires an appropriate storage temperature. Only tested Deep Freezers that operate without any faults or disturbances can guarantee that material such as cell lines or tissue from humans, animals or plants, blood and /or blood fractions, vaccines or reference strains from micro-organisms such as bacteria, yeasts, viruses and fungi will be protected and stored safely and reliably.

The extensive reference list of more than 1400 addresses of well-known users of GFL Deep Freezers in Germany alone attests to this customer requirements for quality and reliability, dependability, long service life and functionality as needed for the application at hand. These are the characteristics that research institutes, universities, hospitals, blood banks and pharmaceutical and chemical companies have come to trust in GFL Freezers. And of course there are a number of companies that use more than just one GFL Deep Freezer.

Our Deep Freezers are also frequently used for various material tests, such as for quality assurance testing of plastics and adhesives, paints and varnishes, ball bearings or road paving materials.

GFL Chest and Upright Freezers are in service in more than 80 countries throughout the world.

in more than 80 countries



GFL Deep Freezers are manufactured using only high-quality, stringently tested materials that are particularly suitable for ultra-low temperatures. The units are extremely quiet, have been approved with the CE mark, are maintenance-free and have the German TÜV seal for „certified safety“ (GS) based on the Federal German Equipment Safety Code. All designs are subject to change. Special makes available on request.

Certified measuring data according to FDA

For customers whose freezer applications call for particularly stringent observance of quality standards, we supply on request detailed records on spatial and temporal temperature constancy basing on the approval guidelines of the US American Health Authority FDA. The instrument test runs are conducted using a calibrated test section in test bays at the factory. Certified test data are archived for a period of ten years at GFL (Order No. 6965, page 13).

User-friendly microprocessor technique

The keypad for the control panel is only the visible tip of the iceberg of the high-performance microprocessor technique which all GFL units are equipped with. All values and data relevant for safe and reliable storage can be entered or retrieved using the clearly laid out and defined symbols. The actual and set temperatures, or the limits for over and under temperatures, for example, can be checked using the LED display. The same applies to the battery capacity and battery loading level. Active operation of an additionally installed safety cooling system is indicated by two extra LED's.

Any faults that may occur are indicated immediately by optical and acoustic alarms. Possible causes for the fault are signalled by code numbers in the display. The user can also set further alarm options as required. Data settings can be protected against unauthorised access by a key-operated security switch.

6380 Chest Freezer, 70 litres, with storage system consisting of racks and boxes



Upright Freezers / Chest Freezers



6483

Upright Freezer,
300 litres



■ Microprocessor-controlled temperature regulation

The microprocessor-controlled temperature regulator, with digital display of actual and set temperature values and digital setting for specified values, operates maintenance-free and is shock resistant.

The regulator is battery-buffered by a constantly charged NC battery that maintains the display of the actual temperature and the alarm functions for 60 hours in case of a power failure. During operation on the line the battery level and the set temperature can be checked by touch control.

■ Energy-saving cooling unit

The maintenance-free cooling unit, equipped with fully hermetically sealed high-performance compressors and an air-cooled condenser, ensures short cooling times.

The refrigerant is non-flammable. The all-around insulation comprises an up to 150 mm thick, seamless and diffusion-protected foamed-in polyurethane layer. This insulation is an essential precondition for energy-saving operation.

The quietly running compressors only give off around 400 W of heat to the environment at maximum cooling temperature.



6481 Deep Freezer, 96 litres, sub-counter installation possible

■ **Ex-proof inside cabinets**

The inside cabinets are manufactured completely of stainless steel (material No. 1.4301), are corrosion resistant and easy to clean.

They are free from ignition sources - an extremely important aspect when storing media with low flash points - and are ex-proof in accordance with BG-I 850-0, version 02/2009. The cooling air outlet is located at the front of the unit, meaning that explosive gases cannot be drawn in when the lid or door is opened. The magnetic sealing system reliably prevents freezing of the lid or door seals.

All chest lids are balanced and easy to operate. Chest Freezers having a volume of 220 to 500 litres are also equipped with additional insulating cover plates on the cabinet.

Upright Freezers with storage volumes of 300 and 500 litres are equipped with three inside compartments (H 353 mm), each provided with an insulating door to prevent any loss of cold air. Optional shelves can also be installed in the compartments (see page 15).

On request, the cabinet can also be equipped with a set of drawers instead of the inside compartments (see page 13).

■ **Alternative solution: Sub-counter installation**

In daily laboratory practice, especially those Deep Freezers convince that guarantee more than just high-quality protection and reliable longevity of the stored material samples.

Alternative solutions are required that meet customers' demands of practical functionality and flexibility in their range of applications.

The sub-counter Deep Freezers 6441 and 6481 are attractive examples for this philosophy. After removing the

cover plate, the units can easily be integrated into a laboratory bench, thus enabling the storage of frozen materials ready at hand at the work station.

Deep Freezers 6441 and 6481 offer a large storage volume while at the same time requiring little space (96 l cabinet volume / 3 drawers) and operate in temperature ranges from 0 to -40 °C and from -50 °C to -85 °C.

Further details: Accessories / external temperature recorder (page 13) and technical data (pages 16 - 18).



6481 Deep Freezer, 96 litres, with cover plate, as stand-alone unit

Upright Freezers / Chest Freezers



6345
Chest Freezer,
500 litres

■ Powder-coated housing

The housings are made of powder-coated, electrolytically galvanised sheet steel.

As standard, all Deep Freezers come with double wheel swivel castors, two of which can be locked, for transport to the place of use and for mobile applications (castors for models 6441 and 6481).

■ Controlled access

The lids and doors of the freezer units can be locked, making unauthorised removal of material impossible. The easy-to-use control panel provides controlled access through the use of a key-operated security switch, ruling out any inadvertent temperature maladjustment.



■ Multiple alarm messages

As standard, the Deep Freezers come with a potential-free changeover contact for connection to an internal alarm system, or to the central I&C system. They are also provided with a connection for a piezoelectric buzzer for simple remote notification of alarms (max. cable length: 100 m with a cable diameter of 0.14 mm²).

In the event of a fault (e.g. excess temperature, under temperature, loss of power, sensor break/short-circuit, etc.), an optical and acoustic alarm is issued. The cause for the fault is shown in the display as a defined code number.

The limit values for alarms (1 - 20 K) for excess and under temperatures can be set individually by the user. Other optional alarm messages can also be set by the user:

- ▶ Suppression of alarm message after a power failure (0 to 999 minutes); this feature is useful, for example, if emergency backup power systems are tested regularly.
- ▶ Suppression of alarm message on violation of a temperature limit (0 to 999 minutes).
The set value remains stored until the next change is made. This can be useful, for example, when large quantities of refrigerated goods are removed/put into storage frequently.
- ▶ Suppression of alarm message on violation of temperature limits (0 to 999 minutes). The set value is cancelled when the set time expires. This can be useful, for example, when large quantities of refrigerated goods are removed/put into storage only occasionally.

■ Guaranteed supply of spare parts

Spare parts can be delivered from stock for all Deep Freezer models. GFL guarantees their availability for ten years.

■ Intensive quality control

Customers' trust in our products is ensured by our intense quality assurance procedure. This is why GFL Deep Freezers are tested with state-of-the-art testing devices before they leave our factory.



6382 Chest Freezer, 100 litres



6384 Chest Freezer, 300 litres

Special makes

- The service supplied to our customers does not end at the convincing high quality standard of our Deep Freezers. In order to enhance their variability and, thus, the benefits for the user, we also supply customised equipment on request, tailored to the individual requirements of tasks that demand special solutions for storage.



6485 Upright Freezer, 500 litres, custom design with two standard compartments and a large drawer unit made of stainless steel with perforated raised side elements and a 10 mm thick insulating plastic cover with a grip hole. Storage system for test plates and boxes.



Whether it be a microtiter plate, a cryo box or dinosaur bones - handling of particularly small or very large bulky storage goods is facilitated for the individual case at hand by the appropriate drawer, divider or compartment solution.

Sample solutions for storage task:

- ▶ Drawers with modified heights for Upright Freezers
- ▶ Combination of inside compartments/drawers for Upright Freezers
- ▶ Locking systems for inside compartments of Upright Freezers
- ▶ Inside compartment covers made of acrylic glass for Upright Freezers
- ▶ Drawer dividers for Upright Freezers
- ▶ Reinforced shelves for Upright Freezers
- ▶ Cabinet dividers for Chest Freezers
- ▶ Storing tubs in different sizes
- ▶ Specially dimensioned storage systems
- ▶ Installation of additional leadthroughs
- ▶ Installation of additional temperature sensors
- ▶ Separated storage and motor units to allow deep freeze storage in a sensitive working area
- ▶ Equipping of our Deep Freezers with a self-dialling alarm phone system enhances storage safety



6485 Upright Freezers, 500 litres, custom design with five inside compartments and inside doors made of 10 mm thick acrylic glass, with grip hole. Storage system for test plates and boxes.

Accessories

- The range of application for our Deep Freezers is expanded using accessories appropriate for the task at hand. GFL accessories for Chest and Upright Freezers therefore not only enhance the reliability and performance of our range of products, but also improve their economic efficiency.

Safety cooling system

(Refrigerant vessel not included in scope of supply)

A power outage or a fault with the unit can often result in thawing of valuable material samples, usually with the associated financial losses and lost work time.

Safety cooling systems protect against non-regulated rises in temperature by keeping the temperature in the cabinet constant at a freely selectable value (0 to -70° C) by controlled injection of LN₂ or CO₂ when the main cooling system fails.

There are four different cooling systems for two different refrigerants available for protecting highly sensitive materials against uncontrolled warming or thawing. These systems can be installed in Chest Freezers with a volume of at least 70 l and in Upright Freezers starting at a volume of 300 l storage space.

The most commonly used refrigerant for safety cooling systems, and the one which is available nearly everywhere throughout the world, is CO₂.

LN₂ is used in cases the stored material must not come into contact with CO₂.

The four types of cooling systems differ in the power supply used for each system:

- ▶ Versions 6946a and 6947a are designed for connection to a 230 Volt emergency power system (a.c.).



- **Order No. 6946a**
LN₂ safety cooling system for 230 V a.c. (emergency power)
- **Order No. 6946b**
LN₂ safety cooling system for battery-powered operation
- **Order No. 6947a**
CO₂ safety cooling system for 230 V a.c. (emergency power)
- **Order No. 6947b**
CO₂ safety cooling system for battery-powered operation

- ▶ Versions 6946b and 6947b are, in case of a power failure, supplied with power by a battery provided with the system for around 60 hours. The battery is recharged automatically when normal power supply is restored.

Distribution lines are required if two or three CO₂ bottles are connected simultaneously to the freezer unit (see Order No. 6948 and 6949). The CO₂ bottles must be provided with a rising pipe and must not be connected to a pressure limiter.

At a setting of -60° C for the safety cooling, consumption of CO₂ or LN₂ is about 1.2 kg per hour.



- **Order No. 6948**
Distribution line for two CO₂ bottles
- **Order No. 6949**
Distribution line for three CO₂ bottles

Distribution line

(CO₂ bottles not included in scope of supply)

The distribution line for safety cooling system 6947 can be ordered complete with all requisite connectors, tubes and materials for wall mounting.

■ Order No. 6960

Water cooling

A heat exchanger is installed in place of the air-cooled liquefier. The advantage here is that the heat exchanger considerably reduces the heat given off by the unit to the environment, at the same time, expanding the permissible ambient temperature range in which the unit can be operated.

* not in scope of supply

Water supply is regulated by the Freezer. The heat exchanger can be connected to a recirculation system or to the internal water supply system. (Connecting points on unit: outside thread connector for pressure hose 1/2 inch* with lock nut.) A water cooling system can be installed in GFL Deep Freezers with a volume of at least 220 litres.

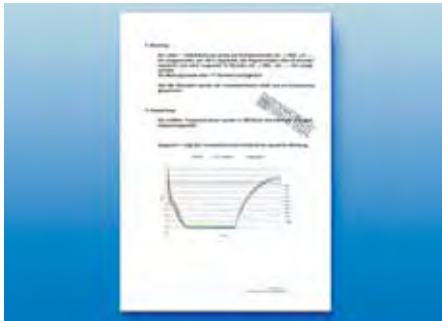

■ Order No. 6965



■ Order No. 6950

for installation

■ Order No. 6951

in a separate housing



■ Order No. 6952

for Upright Freezers 6443 and 6483 (300 l volume)

■ Order No. 6953

for Upright Freezers 6445 and 6485 (500 l volume)

Qualification data record

The GFL qualification data record provides detailed documentation of the spatial and temporal temperature constancy in our Deep Freezers. All requested test and measurement data are established at our factory using a calibrated test section and archived at GFL for one decade.

GFL customers can use this device-specific qualification data record to demonstrate the quality of their products when they must, for example, comply with the special approval guidelines defined by the US American Health Authority FDA.

Chart recorder

The chart recorder ensures continuous recording of the inside cabinet temperature on pressure sensitive paper. The current measured value is recorded with constant, clear legibility without the use of expensive ribbons or ink.

The chart recorder is designed for continuous operation and is equipped with three paper feed options:

- 25 mm in 24 hours
- 25 mm in 2 hours
- 25 mm in 1 hour

Depending on the set feed rate, a roll of paper * for the recorder (9.2 m in total length) will last from 15 to 368 days. Except for easy replacement of the paper rolls, the chart recorder is completely maintenance-free. The recorder can be installed in Chest Freezers with a storage volume of 70 and 100 litres and in Upright Freezers with a storage volume as of 300 litres (Order No. 6950). In combination with the other GFL Freezers the chart recorder is mounted in a separate housing (Order No. 6951).

Drawer sets for Upright Freezers

The cabinet of Upright Freezers can also be equipped with a set of four drawers in place of the three insulated compartments. These drawers are made of stainless steel with front panels made of 10 mm thick polystyrene insulating plates. Ball bearings and slide rails ensure easy and level motion.

* Art. no. 13.608, one roll supplied as standard

Storage system

- The GFL storage system is flexibly structured. Optimised utilization of the storage space is achieved using racks for boxes, microtiter and DeepWell plates, thus reducing the costs per samples that are stored.

The stainless steel racks reduce overall weight and are easy to handle. Use of these drawers guarantees well-arranged and safe storage of the entire sample material.

The box capacity for storing samples can be varied, permitting the system to be adapted to a variety of applications. The boxes are made of water-resistant coated cardboard. There are three different dividers available for the boxes. ►

Boxes (130 x 130 mm) included in the GFL storage system programme:
6970 (H 50 mm) and
6980 (H 75 mm)



Racks included in the GFL storage system programme for boxes, microtiter and DeepWell plates

Inner dividers for boxes 6970 and 6980

- **Order No. 6971 / Division 10 x 10**
for 100 test tubes with a diameter of 11 mm /
section dimensions 12x12 mm
- **Order No. 6972 / Division 8 x 8**
for 64 test tubes with a diameter of 14 mm /
section dimensions 15x15 mm
- **Order No. 6973 / Division 7 x 7**
for 49 test tubes with a diameter of 16 mm /
section dimensions 17x17 mm



Chest Freezers

Model	Volume	Contents	Order No. for 1 box	Number of racks per unit	Order No. for 1 rack	Number of boxes/plates per rack	Number of boxes/plates per unit
6340/6380	70 l	50 mm box height	6970	8	6901	6	48
		75 mm box height	6980	8	6902	4	32
		Microtiter plates	–	12	6905	18	216
		DeepWell plates	–	12	6905	6	72
6342/6382	100 l	50 mm box height	6970	15	6901	6	90
		75 mm box height	6980	15	6902	4	60
		Microtiter plates	–	20	6905	18	360
		DeepWell plates	–	20	6905	6	120
6343/6383	220 l	50 mm box height	6970	18	6903	10	180
		75 mm box height	6980	18	6904	7	126
		Microtiter plates	–	24	6906	30	720
		DeepWell plates	–	24	6906	10	240
6344/6384	300 l	50 mm box height	6970	21	6903	10	210
		75 mm box height	6980	21	6904	7	147
		Microtiter plates	–	30	6906	30	900
		DeepWell plates	–	30	6906	10	300
6345/6385	500 l	50 mm box height	6970	40	6903	10	400
		75 mm box height	6980	40	6904	7	280
		Microtiter plates	–	56	6906	30	1680
		DeepWell plates	–	56	6906	10	560

Upright Freezers

6443/6483	300 l	50 mm box height	6970	24	6907	9	216
		75 mm box height	6980	24	6908	6	144
		Microtiter plates	–	24	6911	36	864
		DeepWell plates	–	24	6911	12	288
6445/6485	500 l	50 mm box height	6970	24	6909	15	360
		75 mm box height	6980	24	6910	10	240
		Microtiter plates	–	24	6912	72	1728
		DeepWell plates	–	24	6912	24	576

Additional shelves for Upright Freezers

Models	Volume	Order No. for one shelf
6443/6483	300 l	6954
6445/6485	500 l	6955

- ▶ Upright Freezers having a storage volume of 300 and 500 litres come with three compartments as standard equipment. As an option, each compartment can be sectioned with one additional shelf for optimal utilisation of the internal volume of the unit.

Technical data

■ The GFL programme for Chest and Upright Freezers, with 18 model options and seven different storage volumes, is the result of more than 40 years of production experience and focuses on uncompromising and perfect safety and reliability.

The following table lists the performance features oriented to the specific requirements for actual every-day use for each of the individual products.

Chest Freezers								
Order No.	Volume	Temperature range °C	Inner dimensions W x D x H mm	Outside dimensions (A) W x D x H mm	Outside dimensions (B) W x D x H mm	Power kW	Net weight approx. kg	Packing volume approx. m ³
6340	70	± 0 to -40	600x 350x 340	836x 685x1055	836x 585x1055	0.6	100	1.1 ●
6341	30	± 0 to -40	500x 305x 200	700x 600x 905	700x 500x 905	0.6	70	0.6 ■
6342	100	± 0 to -40	710x 440x 340	960x 790x1080	960x 690x1080	0.6	180	1.9 ●
6343	220	± 0 to -40	840x 460x 580	1450x 870x1040	1450x 770x1040	0.6	210	3.0 ●
6344	300	± 0 to -40	1000x 500x 600	1610x 910x1060	1610x 810x1060	0.6	240	3.0 ●
6345	500	± 0 to -40	1440x 580x 600	2060x1000x1060	2060x 900x1060	0.6	310	3.4 ●
6380	70	-50 to -85	600x 350x 340	836x 685x1055	836x 585x1055	1.2	120	1.1 ●
6381	30	-50 to -85	500x 305x 200	700x 600x 905	700x 500x 905	1.2	90	0.6 ■
6382	100	-50 to -85	710x 440x 340	960x 790x1080	960x 690x1080	1.2	200	1.9 ●
6383	220	-50 to -85	840x 460x 580	1450x 870x1040	1450x 770x1040	1.2	230	3.0 ●
6384	300	-50 to -85	1000x 500x 600	1610x 910x1060	1610x 810x1060	1.2	260	3.0 ●
6385	500	-50 to -85	1440x 580x 600	2060x1000x1060	2060x 900x1060	1.2	330	3.4 ●
Upright Freezers								
6441	96	± 0 to -40	430x 430x 510	900x 770x 890	900x 770x 865	0.45	140	1.1 ●
6443	300	± 0 to -40	600x 450x1100	990x 865x1940	916x 785x1940	0.6	240	2.8 ●
6445	500	± 0 to -40	600x 760x1100	990x1175x1940	916x1095x1940	0.6	310	3.5 ●
6481	96	-50 to -85	430x 430x 510	900x 770x 890	900x 770x 865	0.9	150	1.1 ●
6483	300	-50 to -85	600x 450x1100	990x 865x1940	916x 785x1940	1.2	270	2.8 ●
6485	500	-50 to -85	600x 760x1100	990x1175x1940	916x1095x1940	1.2	340	3.5 ●
230 V one-phase voltage a.c. / 50 Hz (other voltages and frequencies on request)						All designs are subject to change without notice		

Delivered free German border, fas German seaport or fca German airport including packing in:

- = cardboard box
- = wooden crate,

shipment through GFL's forwarders. If other forwarders are to be used, we deliver ex works.

Sometimes, narrow doors demand smaller unit widths and/or depths when the Freezers are transported to the place of use. The product table (P. 14) shows both dimensions (A and B), illustrated on this page.

Chest Freezers / Upright Freezers:

The **outside dimensions (A)** given here are the actual dimensions.

Chest Freezers: The **outside dimensions (B)** given here refer to the depth dimension after removing the lock and the lid hinges, the cable connections and the connector for the safety cooling system, the chart recorder, the power switch and the control panel; with the height dimensions referring to when the lid is opened.

Upright Freezers: The **outside dimensions (B)** given here refer to the width dimensions after removing the lock and to the depth dimensions without the cable connection and the connector for the safety cooling system, the chart recorder, power switch and control panel.

Chest Freezers

Models **6343, 6344, 6345, 6383, 6384, 6385** with 220, 300 and 500 litres storage volume

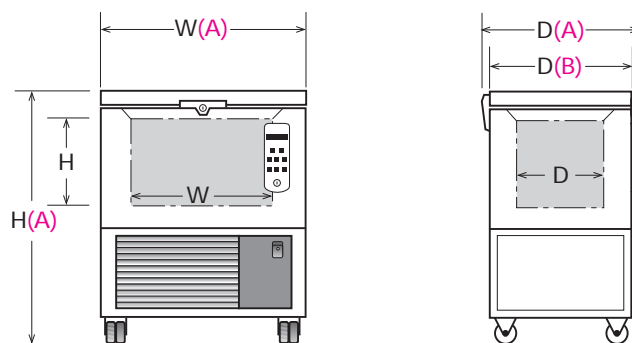
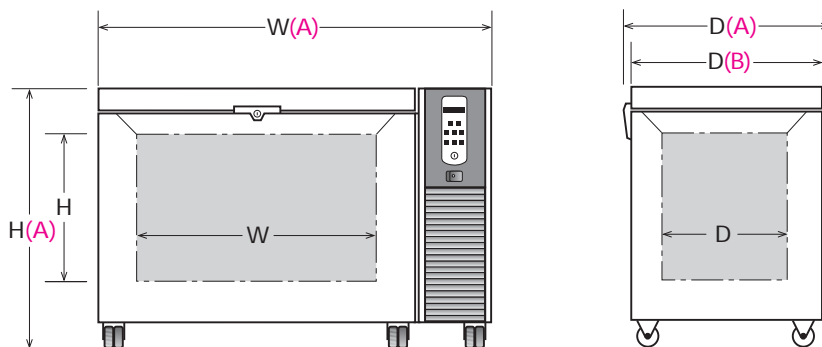

Chest Freezers

Models **6340, 6341, 6342, 6380, 6381, 6382** with 30, 70 and 100 litres storage volume

Upright Freezers

Models **6443, 6445, 6483, 6485** with 300 and 500 litres storage volume

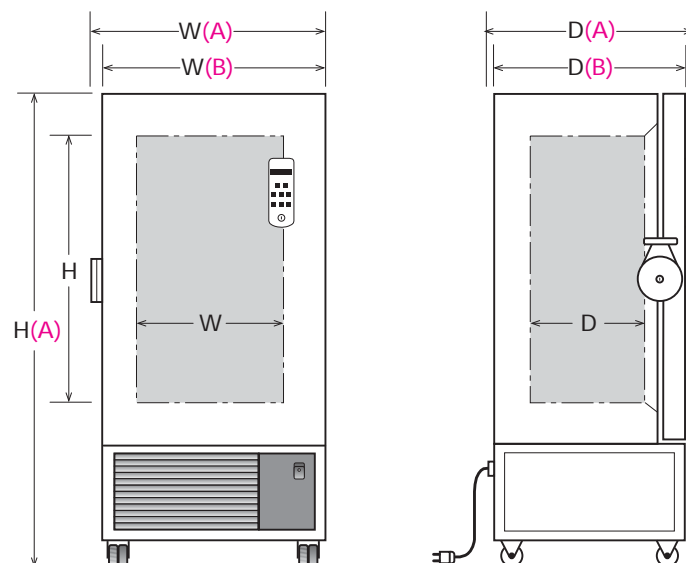

Sometimes, narrow doors demand smaller unit widths and/or depths when the Freezers are transported to the place of use. The product table (page 16) shows both dimensions (A and B), illustrated on this page.

Upright Freezers 6441 and 6481 (suitable for sub-counter installation):

The **outside dimensions (A)** given here are the actual dimensions.

The **outside dimensions (B)** given here refer to the height with the cover plate removed.

The Upright Freezers require **a distance of at least 60 mm** from other units or walls, thus providing sufficient cooling air supply.

Upright Freezers

Models **6441** and **6481**
with 96 l storage volume,
suitable for sub-counter
installation

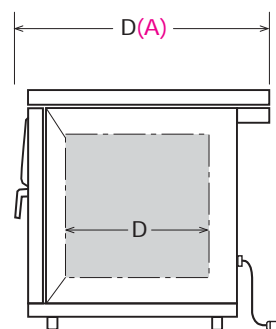
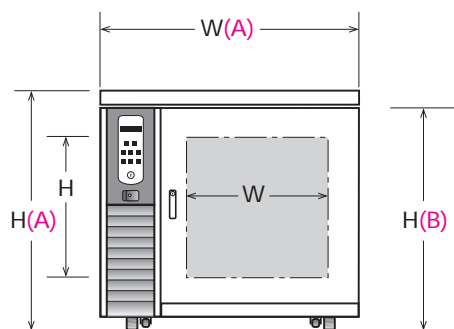
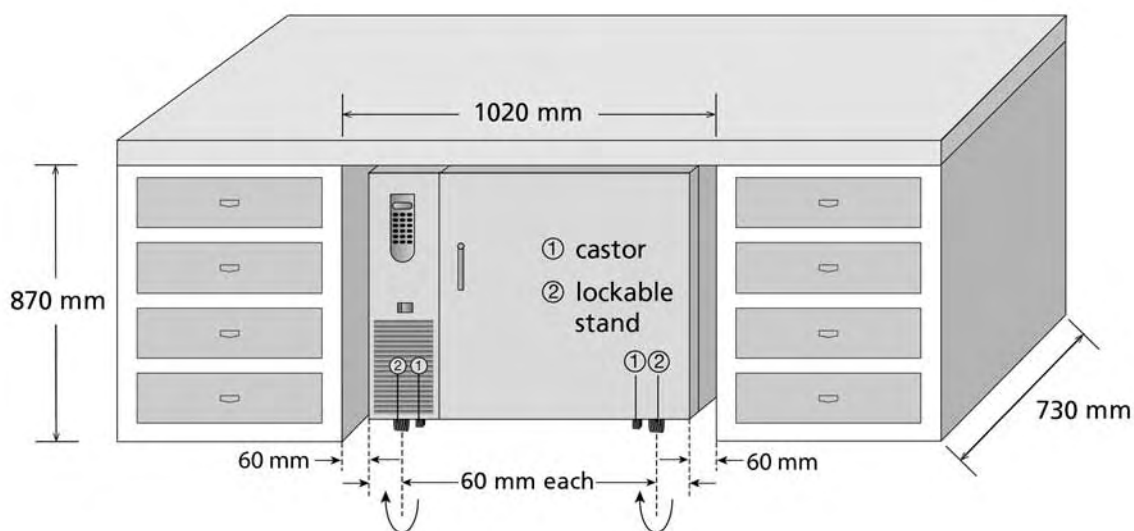

Water Baths

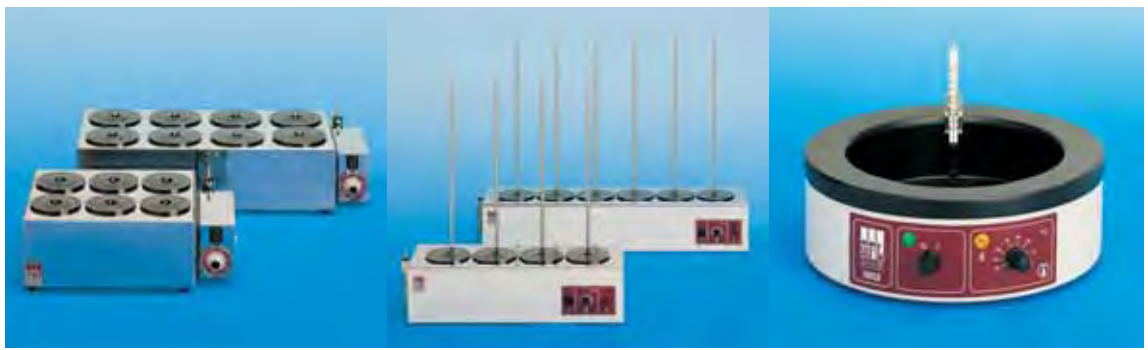

■ Convincing quality features stand for a practice-proven range of 13 special Water Baths that guarantee reliable temperature examinations, independent of their field of application.



Quality built on Tradition

Users in research labs, standard and special labs for medicine, science and industry throughout the world have been profiting from the precision and dependability of our products for 45 years, all of which comply with valid European standards and bear the CE mark.

In the future, the success of a product spectrum of laboratory devices that meet the toughest demands on material, functioning and design will continue to be ensured by experience of every-day use in detail, ongoing technical advances and an excellent quality approach.

The phrase „Quality built on Tradition“ encompasses more than just the sum of impressive product innovations. It is also an expression of our corporate policy, which includes a high degree of ready-and-waiting service as our primary customer-friendly service goal.

This applies to all of the GFL laboratory products that are produced exclusively at our plant in Germany - Deep Freezers, Shakers, Shaking Water Baths, Water Stills, Incubators or Water Baths alike.



Secure future

A vested quality demand in accordance with international standards is documented for all GFL laboratory products with the certification to DIN EN ISO 9001:2008, promoting more trust in the permanent high quality level of our products.

In addition to the continuous optimisation of ongoing production processes, the ISO obligation also calls for the commitment to quality awareness of our employees and the continuous development and rapid implementation of preventive measures to ensure quality assurance at a high level.

Valued as universal laboratory aids



In daily practice, GFL Water Baths have been valued for decades as a robust and universal aid for reliable temperature examinations in laboratories. They prove themselves daily in various fields of application – no matter whether they are used as

Incubation or Inactivation WaterBaths, as Steam Baths, as Water Baths for fume hoods, Multiple Water Baths or as a Tissue Float Bath. All GFL Water Baths are tested according to the German Equipment Safety Law and have the CE mark.

The accessories shown in this brochure are not included in the standard scope of supply of the units. The right of constructional modifications remains reserved. Special makes are available.

Contents

Product-No.		Page	Accessories / Page
1002 to 1008	Incubation/Inactivation Baths	24/25	26/27
1012 and 1013	Incubation/Inactivation Baths with circulation system	24/25	27
1023	Steam Bath	28	28
1031 and 1032	Water Baths for fume hoods	29	–
1041 and 1042	Multiple Water Baths	30	–
1052	Tissue Float Bath	31	31

1002 - 1008

Successfully used

The range of Incubation and Inactivation Baths comprises seven models with five different sizes of 7 to 40 l capacity.

Water Bath 1005 is especially suitable for warming medical hot packs.

Water Baths 1012 and 1013 are equipped with a circulation system, thus guaranteeing an optimal temperature uniformity.

Specifications and features

- ▶ Short heating-up times.
- ▶ Temperature display and setting digitally via LED display, in 0.1 °C increments. Fast and exact setting, exact reproducibility of the set value.
- ▶ Electronic monitoring of the temperature regulator. In case of failure, the cause of the fault is shown on the display.
- ▶ Soft-touch keys with clear symbols. Two-finger operation prevents unintentional alterations of the set value.
- ▶ Interior (bath interior and heating element, cover frame, lid and perforated floor) made of stainless steel. Standard equipment: lid and perforated floor. Water Bath 1005 is supplied without perforated floor if the rack for hot packs 1923 (accessory) is ordered.



1005 Water Bath, 40 litres



1003 Water Bath, 14 litres

Technical data

Model Order No.	Interior dimensions			Exterior dimensions			Capacity approx. litres	Electrical connection*	Weight approx.		Packing volume approx m ³
	Width mm	Depth mm	Working height † mm	Width mm	Depth mm	Height mm			net kg	gross kg	
1002	245	200	145	330	395	255	7	230 V / 50...60 Hz / 1.0 kW	9	11	0.11
1003	400	245	145	485	440	255	14	230 V / 50...60 Hz / 1.5 kW	12	15	0.13
1004	600	245	145	685	440	255	21	230 V / 50...60 Hz / 1.5 kW	17	21	0.26
1005	410	296	315	495	490	445	40	230 V / 50...60 Hz / 1.5 kW	21	27	0.30
1008	400	245	205	485	440	325	20	230 V / 50...60 Hz / 1.5 kW	14	17	0.13

† perforated floor to upper rim

* Other voltages available on request

1012 / 1013

- ▶ Cover frame and lid have mirror finish. Lift-up, insulating lid with inner camber, no dripping back of condensate into the tubes.
- ▶ Corrosion-resistant outer housing, made of electrolytically galvanised sheet steel, powder-coated. Drain cock at the back.

Applications

All Water Baths models 1002 to 1013 are successfully used for incubations and inactivations of cultures, such as e.g. for warming bacteriological media, carrying out chemical reactions or thawing samples.

The circulation system of Water Baths 1012 and 1013 ensures optimum temperature uniformity throughout the whole bath. An electric motor with rotary magnet is flanged to the bath floor. Its torque is transmitted to a PTFE coated stirring magnet in the bath. The stirring magnet forces the water into the centre of the bath and then evenly back again.

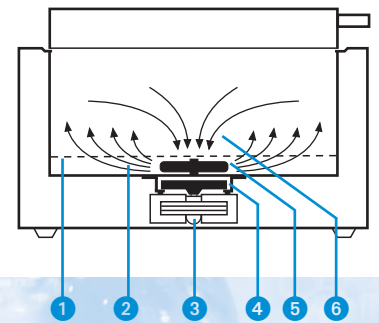

- 1 Perforated floor
- 2 Water circulation
- 3 Motor
- 4 Rotary magnet
- 5 Stirring magnet
- 6 Water circulation



1013 Water Bath with circulation system, 14 litres

Additional technical data of models 1002 - 1013

Temperature regulation:	Microprocessor-controlled
Temperature constancy:	±0.1 °C temporal
Temperature range:	approx. 5 °C above ambient temperature to +99.9 °C
with water level regulator 1919:	approx. 3 °C above tap water temperature to +99.9 °C
Over-temperature cut-out:	electronic, 4 °C above set temperature and electro-mechanical >130 °C

Technical data

Model Order No.	Interior dimensions			Exterior dimensions			Capacity approx. litres	Electrical connection*	Weight approx.		Packing volume approx m ³
	Width mm	Depth mm	Working height [◆] mm	Width mm	Depth mm	Height mm			net kg	gross kg	
1012	245	200	145	330	395	325	7	230 V / 50...60 Hz / 1.0 kW	10	12	0.11
1013	400	245	145	485	440	325	14	230 V / 50...60 Hz / 1.5 kW	14	17	0.13

◆ perforated floor to upper rim

* Other voltages available on request

Accessories



1002-1008



Test Tube Rack
made of stainless steel,
with 20 openings of 18 mm Ø,
for test tubes of 16/17 mm Ø,
max. height 185 mm

Order No. 1920

Capacities:

Water Bath 1002	4 racks =	80 test tubes
Water Bath 1003 / 1008	8 racks =	160 test tubes
Water Bath 1004	12 racks =	240 test tubes
Water Bath 1005	9 racks =	180 test tubes



Test Tube Rack
made of stainless steel,
with 5 openings of 31 mm Ø,
max. height 185 mm

Order No. 1921

Capacities:

Water Bath 1002	4 racks =	20 test tubes
Water Bath 1003 / 1008	8 racks =	40 test tubes
Water Bath 1004	12 racks =	60 test tubes
Water Bath 1005	9 racks =	45 test tubes



Test Tube Rack
made of stainless steel,
with 20 openings of 13 mm Ø,
for test tubes of 12 mm Ø,
max. height 185 mm

Order No. 1922

Capacities:

Water Bath 1002	4 racks =	80 test tubes
Water Bath 1003 / 1008	8 racks =	160 test tubes
Water Bath 1004	12 racks =	240 test tubes
Water Bath 1005	9 racks =	180 test tubes



Milk Bottle Rack
made of stainless steel,
with 12 openings of 56 mm Ø,
for baby milk bottles

Order No. 1942

Capacities:

Water Bath 1002	1 rack =	12 bottles
Water Bath 1003 / 1008	2 racks =	24 bottles
Water Bath 1004	3 racks =	36 bottles
Water Bath 1005	2 racks =	24 bottles



**Adjustable
Water Level Regulator**
to keep the water level constant
and to cool Water Baths 1002-
1008 (approx. 3 °C above tap
water temperature)

Order No. 1919



1005



Rack for Water Bath 1005
made of stainless steel,
especially suitable for warming
medical hot packs.

Order No. 1923

Capacities:

Water Bath 1005	up to 8 hot packs
-----------------	-------------------



1012/1013



Test Tube Rack
made of stainless steel,
with 20 openings of 18 mm Ø,
for test tubes of 16/17 mm Ø,
max. height 185 mm

Order No. 1920

Capacities:

Water Bath 1012 4 racks = 80 test tubes
Water Bath 1013 8 racks = 160 test tubes



Test Tube Rack
made of stainless steel,
with 5 openings of 31 mm Ø,
max. height 185 mm

Order No. 1921

Capacities:

Water Bath 1012 4 racks = 20 test tubes
Water Bath 1013 8 racks = 40 test tubes



Test Tube Rack
made of stainless steel,
with 20 openings of 13 mm Ø,
for test tubes of 12 mm Ø,
max. height 185 mm

Order No. 1922

Capacities:

Water Bath 1012 4 racks = 80 test tubes
Water Bath 1013 8 racks = 160 test tubes



Milk Bottle Rack
made of stainless steel,
with 12 openings of 56 mm Ø,
for baby milk bottles

Order No. 1942

Capacities:

Water Bath 1012 1 rack = 12 bottles
Water Bath 1013 2 racks = 24 bottles



**Adjustable
Water Level Regulator**
to keep the water level constant
and to cool Water Baths 1012-
1013 (approx. 3 °C above tap
water temperature)

Order No. 1919

1002-1013



Water Bath Protection Agent
ProAquaTop prevents the forma-
tion of algae, bacteria and
mould. Biodegradable and non-
toxic.

Highly efficient: only 1 ml per litre of water. A necessary change of
water is indicated by fading of the blue colouration

Order No. 1910

Packing unit 1 bottle / Contents 200 ml.

Order No. 1911

Packing unit 3 bottles / Contents 3 x 200 ml

Order No. 1912

Packing unit 6 bottles / Contents 6 x 200 ml



Lid with openings
made of stainless steel, with sets
of rings made of heat-resistant
plastic material. Number and
diameter of openings can be
chosen between 52 and 192
mm, in steps of 20 mm.

Example

Increases the variability of the
Water Bath and reduces the loss
of heat when placing large
vessels into the Bath

Price available on request

please state number and
diameter of openings

1023

Indispensable

For gentle steaming work with Erlenmeyer flasks, glasses, etc., GFL Water Baths models Steam Bath 1023 and Water Baths for fume hoods 1031 and 1032 have become indispensable in daily practice.

Accessories



Test Tube Rack
made of stainless steel,
with 100 openings of Ø 18 mm,
for test tubes

Order No. 1933



Support Rod
made of stainless steel,
length 316 mm, Ø 12 mm

Order No. 1985

GFL Water Baths convince through their varied ranges of application. For instance, the Steam Bath's square cover frame (W 265 mm x L 265 mm) is removable. Its 9-part set of rings, made of heat-resistant plastic material can be parted. Its diameter can be varied in approx. 20 mm steps (min. 32.5 / max. 173.5 mm).

1023 Steam Bath, 7 litres



Technical data

Model Order No.	Interior dimensions			Exterior dimensions			Capacity approx. litres	Electrical connection*	Weight approx.		Packing volume approx m ³
	Width mm	Depth mm	Working height mm	Width mm	Depth mm	Height mm			net kg	gross kg	
1023	240	240	120	342	400	180	7	230 V / 50...60 Hz / 1.0 kW	9	12	0.10

◆ perforated floor to upper rim

* Other voltages available on request

1031 / 1032

Applications

Water Baths for fume hoods 1031 / 1032 are special baths that are preferably used for protected applications in fume hoods (digestories).

Specifications and features

- ▶ Temperature range from approx. 5°C above ambient to boiling point, temperature regulation through tension thermostat. Heating element protected by over-temperature cut-out.
- ▶ 1023: bath, cover frame and perforated floor above the heating element are made of stainless steel.
- ▶ 1023: the adjustable water level regulator is situated at the back of the unit. It is part of the standard scope of supply, as well as the set of rings made of heat-resistant plastic material.
- ▶ 1023: outer housing made of electrolytically galvanised sheet steel, powder-coated.
- ▶ 1031/1032: bath, removable recessed lid with holes and perforated floor above the heating element are made of stainless steel.
- ▶ 1031/1032: the adjustable water level regulator at the right-hand side of the unit is part of the standard scope of supply.
- ▶ 1031/1032: the openings in the lid are covered by sets of rings made of heat-resistant plastic material.
- ▶ 1031/1032: four non-slip plastic feet ensure great stability.



1031 Water Bath for fume hoods

1032 Water Bath for fume hoods

Technical data

Model Order No.	Openings with sets of rings	Ø of the openings mm	Working height [◆] mm	Exterior dimensions			Electrical connection*	Weight approx.		Packing volume approx. m ³
				Width mm	Depth mm	Height mm		net kg	gross kg	
1031	6	91	100	430	300	155	230 V / 50...60 Hz / 1.5 kW	6.1	7.4	0.05
1032	8	111	100	670	300	155	230 V / 50...60 Hz / 1.5 kW	8.2	10.2	0.24

◆ perforated floor to upper rim

* Other voltages available on request

1041/1042

Especially suitable

GFL Multiple Water Baths 1041 / 1042 are especially suitable for gentle steaming work with columns, Erlenmeyer flasks or beakers. Even after years of continuous operation they remain to be the most reliable laboratory aids.

Specifications and features

- ▶ Temperature range from approx. 5 °C above ambient to boiling point, temperature regulation through tension thermostat. Heating element protected by over-temperature cut-out.
- ▶ Bath interior, frame with openings and parted perforated floor above the heating element are made of stainless steel.
- ▶ The openings in the frame have a diameter of 130 mm and are covered by sets of rings made of heatresistant plastic material.
- ▶ A support rod of 600 mm length and a diameter of 12 mm, made of stainless steel, is situated behind each opening. It serves to fix the steaming vessels securely.
- ▶ The adjustable water level regulator is on the left-hand side of the bath. It is included in the standard scope of supply of the units.
- ▶ Outer housing made of electrolytically galvanised sheet steel, powder-coated.

Applications

Chemical, clinical and biological laboratories, both in research and industry, decide on our Multiple Water Baths whenever special quality and quantity requirements are to be fulfilled.

1042 Multiple Water Bath



1041 Multiple Water Bath

Technical data

Model Order No.	Openings with sets of rings	Ø of the openings mm	Working height [◆] mm	Exterior dimensions			Electrical connection*	Weight approx.		Packing volume approx. m ³
				Width mm	Depth mm	Height mm		net kg	gross kg	
1041	4	131	90	682	232	190	230 V / 50...60 Hz / 1.0 kW	12	15	0.12
1042	6	131	90	982	232	190	230 V / 50...60 Hz / 1.5 kW	16	20	0.15

◆ perforated floor to upper rim

* Other voltages available on request

■ Preferential choice

Special bath Tissue Float Bath model 1052 reliably fulfills everyday tasks in laboratories. Its exact temperature regulation ensures evenly stretched cuttings which are clearly visible in the black anodised bath. The cuttings are carefully dried on the warmed rim of the bath, which is also black anodised.

Specifications and features

- ▶ Exact temperature constancy of $\pm 0.5^\circ \text{C}$.
- ▶ Temperature range from approx. 5°C above ambient to approx. $+80^\circ \text{C}$.
- ▶ The low 100 mm height of the bath allows comfortable and safe working.
- ▶ Bath interior made of aluminium, black anodised. Housing made of aluminium, powder-coated, with knob and scale of the temperature regulator, mains switch and two pilot lamps (green/yellow, for mains and heating).
- ▶ The control thermometer with stainless steel holder is fixed on the rim of the bath.

Accessory



Dust guard lid
made of aluminium,
black anodised

Order No. 1950

Applications

Histological, chemical, clinical and bacteriological laboratories use this special bath to stretch and dry cut tissues.



Technical data

Model Order No.	Temperature range to	Interior dimensions Ø / H mm	Exterior dimensions Ø / H mm	Electrical connection*	Weight approx. net kg	Weight approx. gross kg	Packing volume approx m ³
1052	ca. $+80^\circ \text{C}$	200 / 60	280 / 100	230 V / 50...60 Hz / 0.3 kW	2	5	0.03

* Other voltages available on request

Summary of Laboratory Products



- Chest Freezers Page 3
- Upright Freezers Page 3
- Water Baths Page 21
- Tissue Float Bath Page 31
- Shaking Water Baths Page 33
- THERMOLAB® Page 38
- Incubators Page 41
- Shaking Incubators Page 44
- Hybridisation Incubator Page 48
- Mini Incubator Page 50
- Tube Roller Incubator Page 50
- Shakers Page 53
- Test Tube Rotator Page 64
- Rotating Shaker Page 65
- Water Stills Page 71

Would you like to find out more details about our range of products?

Phone: ++ 49 - 5139 99 58 - 0

Fax: ++ 49 - 5139 99 58 21

E-Mail: info@GFL.de

Internet: www.GFL.de

Shaking Water Baths THERMOLAB®

GFL®



■ "Precision in series" - a synonym for a specialised range of four Shaking Water Baths that are in use all over the world



Quality built on Tradition

Users in research labs, standard and special labs for medicine, science and industry throughout the world have been profiting from the precision and dependability of our products for 45 years, all of which comply with valid European standards and bear the CE mark.

In the future, the success of a product spectrum of laboratory devices that meet the toughest demands on material, functioning and design will continue to be ensured by experience of every-day use in detail, ongoing technical advances and an excellent quality approach.

The phrase „Quality built on Tradition“ encompasses more than just the sum of impressive product innovations. It is also an expression of our corporate policy, which includes a high degree of ready-and-waiting service as our primary customer-friendly service goal.

This applies to all of the GFL laboratory products that are produced exclusively at our plant in Germany - Deep Freezers, Shakers, Incubators, Water Stills, Water Baths or Shaking Water Baths alike.



Secure future

A vested quality demand in accordance with international standards is documented for all GFL laboratory products with the certification to DIN EN ISO 9001:2008, promoting more trust in the permanent high quality level of our products.

In addition to the continuous optimisation of ongoing production processes, the ISO obligation also calls for the commitment to quality awareness of our employees and the continuous development and rapid implementation of preventive measures to ensure quality assurance at a high level.





Specialists for special demands



The product range of GFL Shaking Water Baths comprises four models, all of them specialised in different work processes. Models 1083 / 1086 are designed for reciprocating motions, model 1092 for orbital motions. Shaking Water Bath 1070,

with the patented brand name THERMOLAB®, has four individually heatable basins and satisfies the most sophisticated demands, too. GFL Shaking Water Baths are in use all over the world. They are regarded as highly reliable, with a superb performance and they are maintenance-free. Shaking Water Baths 1083 - 1092 have been tested according to the

German Equipment Safety Law, and all units bear the CE mark. The accessories to accommodate a variety of vessels can be easily and safely fixed in their shaking devices. The accessories shown in this brochure are not part of the standard scope of supply. The right of constructional modifications is reserved. Special makes are possible.

Contents	Product-No.	Motion	Page
	1083	 with reciprocating motion	36-37
	1086	 with reciprocating motion	36-37
	1092	 with orbital motion	36-37
	1070 THERMOLAB®	 with reciprocating motion	38
	Accessories		39

Shaking Water Baths by GFL are untiring

■ Precision in series

GFL Shaking Water Baths are regarded as untiring all-purpose experts.

Our product range is designed for precise heating-up processes and, simultaneously, gentle mixing or vigorous shaking.

Models 1083, 1086 (with reciprocating motion) and 1092 (with orbital motion) are equipped with digital display of temperature and, according to the specifications, with digital display of shaking frequency and a cooling coil.



1083

Technical Data

Temperature range:

approx. 5 °C above ambient to +99.9 °C

with water level regulator 1919: approx.
3 °C above tap water temperature to +99.9 °C

Temperature constancy (temporal): $\pm 0,1$ °C

Shaking motion: reciprocating,
with on / off switch

Shaking amplitude: 22 mm

Exterior dimensions (W x D x H):
715 x 520 x 330 mm

Net / gross weight: 28 / 32 kg

Packing volume: approx. 0.29 m³

■ Order No. 1083

Specifications and Features

- ▶ Microprocessor-controlled temperature regulation ensures fast heating up to the set temperature and an excellent temperature constancy: ± 0.1 °C, temporal
- ▶ Optimum temperature distribution throughout the whole bath interior
- ▶ Temperature display and setting digitally via LED display, in 0.1 °C increments. Fast and exact setting, exact reproducibility of the preset temperature
- ▶ Electronic monitoring of the temperature controller. In case of a fault, the cause is displayed on the LED.

- ▶ Over-temperature cut-out: electronic, 4 °C above set temperature, and electro-mechanical > 130 °C
- ▶ Constant shaking frequency, independent of load, even when in continuous operation
- ▶ Maintenance-free and durable shaking device, electronically controlled and continuously settable shaking motion, gentle start-up. In models 1083 and 1086, the shaking device is guided on corrosion-resistant special ball bearings.
- ▶ Easily removable shaking rack
- ▶ Bath interior and shaking rack made of stainless steel

- ▶ No dripping back of condensate into the vessels due to double-walled insulating lid with interior camber
- ▶ Drain cock to empty the bath

Applications

Whenever exactly reproducible temperatures are required for shaking tasks, our Shaking Water Baths are used by standard and research laboratories. Their scope of applications comprises incubations, fermentations, homogenisations, chemical and biochemical reactions, enzyme and tissue studies.

all-purpose experts

1092

Technical Data

Temperature range:

approx. 5 °C above ambient to +80 °C

with water level regulator 1919: approx.

3 °C above tap water temperature to +80 °C

Temperature range: +10 °C to +80 °C

Cooling coil: built-in as standard, for connection to the water mains or to an external recirculating chiller

Temperature constancy (temporal): $\pm 0,1$ °C

Shaking motion: orbital, with on / off switch

Shaking amplitude: 14 mm

Shaking frequency display: digital-LED

Exterior dimensions (W x D x H):

635 x 505 x 400 mm

Net / gross weight: 35 / 40 kg

Packing volume: approx. 0.34 m³

■ Order No. 1092



1086

Technical Data

Temperature range:

approx. 5 °C above ambient to +99.9 °C

with water level regulator 1919: approx.

3 °C above tap water temperature to +99.9 °C

Temperature range: +10 °C to +99.9 °C

Cooling coil: built-in as standard, for connection to the water mains or to an external recirculating chiller

Temperature constancy (temporal): $\pm 0,1$ °C

Shaking motion: reciprocating, with on / off switch

Shaking amplitude: 22 mm

Shaking frequency display: digital-LED

Exterior dimensions (W x D x H):

715 x 520 x 330 mm

Net / gross weight: 30 / 34 kg

Packing volume: approx. 0.29 m³

■ Order No. 1086



Additional technical data of models 1083 / 1086 / 1092

Interior dimensions (W x D x H): 450 x 300 x 160 mm

Volume of bath interior: approx. 20 litres

Working height (incl. lid): 190 mm

Max. water level above shaking cage / tray: 105 mm / 90 mm

Shaking frequency: from 10 - 250 rpm

Over-temperature cut-out: electronic, 4 °C above set temperature, and electro-mechanical > 130 °C

Housing: corrosion-resistant, made of electrolytically galvanised sheet steel, powder-coated

Electrical connection: 230 V / 50...60 Hz / 1.5 kW *
* Other voltages on request

1070

Individual and special

THERMOLAB[®], a quadrothermal Shaking Water Bath with reciprocating motion, possesses an exceptional individuality in the market. It disposes of four separate basins in which different sample vessels can be heated independently of each other, or which four different users can use at the same time - saving both working space and time.

Height-adjustable sample holder with rack for reaction vessels of 1.5 - 2.0 ml



Double-walled lid with inner camber have insulating capacity and prevent dripping back of condensate into the vessels

Specifications and Features

- ▶ Microprocessor-controlled temperature regulation ensures fast heating up to the individually set temperature and an excellent temperature constancy: ± 0.1 °C temporal
- ▶ Electronic monitoring of the temperature controller. In case of a fault, the cause is displayed on the LED.
- ▶ Bath interior and shaking rack are made of stainless steel
- ▶ Maintenance-free and durable shaking device, electronically controlled and continuously settable shaking motion, gentle start-up.
- ▶ With the use of optional racks or directly on the sample holders, all kinds of vessels from μ l to ml used in laboratories, microtiter plates, cyler tubes, Western Blot vessels, centrifuge tubes, ampoules and bottles can be fixed.

Technical Data

Temperature range:
approx. 5 °C above ambient to 99.9 °C

Temperature setting and display: digital-LED

Over-temperature cut-out:
electronic 4 °C above set temperature, and electro-mechanical > 130 °C

Shaking motion: reciprocating, with on / off switch

Shaking frequency: from 2 - 50 rpm

Shaking amplitude: 22 mm

Working height: 80 mm

Sample holders, height-adjustable: 32 mm

Dimensions sample holders: 128 x 128 mm

Interior dimensions (W x D x H) per basin:
175 x 175 x 100 mm

Exterior dimensions (W x D x H):
625 x 556 x 270 mm

Electrical connection:
230 V / 50...60 Hz / 1,3 kW

Net / gross weight: 28 / 36 kg

Packing volume: approx. 0.34 m³

Order No. 1070



Applications

THERMOLAB[®] is universally applicable in standard, research and specialised laboratories; for example for all temperature-dependent reactions, for incubations of reagents and solutions, Enzyme-Immuno-Essays, Western-Blots, Reverse Dot Blots, for hybridisations at four different temperatures, for stringent washing processes with variable temperatures, Restriction Enzyme Digestions, Proteinase-K Digestions, DNA Elution, T 7 Sequenase Sequencing, for thawing processes and incubations of cultures or for polymerase chain reactions (PCR).

Shaking Water Baths 1083 / 1086 / 1092



Order No. 3960

Shaking Tray

made of stainless steel, with holes to accept clamps for Erlenmeyer flasks and other accessories. The tray has two handles that reach above the water's surface, for easy inserting and removing from the bath

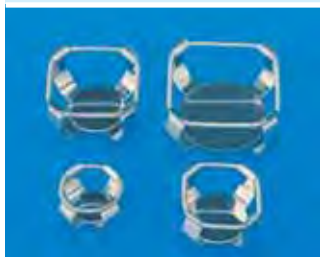

Clamps for Erlenmeyer flasks

made of stainless steel, to screw onto shaking tray 3960, supplied complete with fixing material

- Order No. 3983 for 25 ml flasks (52*)
- Order No. 3984 for 50 ml flasks (33*)
- Order No. 3985 for 100 ml flasks (22*)
- Order No. 3986 for 200 ml flasks (15*)
- Order No. 3987 for 250-300 ml flasks (13*)
- Order No. 3988 for 500 ml flasks (10*)
- Order No. 3989 for 1000 ml flasks (6*); raised lid required, price on request

* maximum quantity of clamps per shaking tray

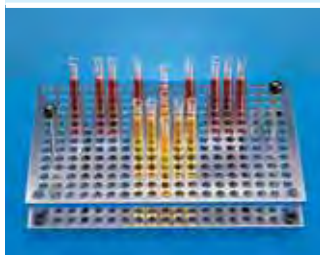

Test Tube Racks

made of stainless steel, with two handles that reach above the water's surface, for easy inserting and removing from the bath

- Order No. 3920 for max. 243 tubes, Ø 16/17 mm, max. length 180 mm
- Order No. 3921 for max. 63 tubes, Ø 31 mm
- Order No. 3922 for max. 372 tubes, Ø 12 mm, max. length 180 mm



Order No. 3923

Rack

made of stainless steel, raised tray, with 6 holding frames for test plates



Holder for 58 reaction vessels

1.5 - 2.0 ml, with float protection, made of stainless steel, can be screwed onto tray 3960

Order No. 3926 max. 3 holders per tray

Accessories



Test Tube Racks

made of stainless steel. The holding device can be tilted by an angle of 90 ° and is equipped with springs for secure support. It can be screwed onto shaking tray 3960

- Order No. 3924 for example for Falcon tubes 15 ml, for max. 20 tubes Ø 12-17 mm, max. 4 racks per tray
- Order No. 3925 for example for Falcon tubes 50 ml, for max. 12 tubes Ø 25-29 mm, max. 3 racks per tray



Adjustable Water Level Regulator

to maintain a desired level of water (1083 / 1086 / 1092) and to cool Shaking Water Bath 1083 (from approx. 3 °C above tap water temperature)

Order No. 1919

THERMOLAB® 1070

Racks



for test tubes 50 ml
with 7 bore holes of 31 mm Ø each
Order No. 1710



for test tubes 15 ml
with 19 bore holes of 17 mm Ø each
Order No. 1711



for reaction vessels 1.5 - 2.0 ml
with 32 bore holes of 12 mm Ø each
Order No. 1712

1083 / 1086 / 1092 / 1070



Water Bath Protection Agent

ProAquaTop prevents the formation of algae, bacteria and mould. Biodegradable and non-toxic.

Highly efficient: only 1 ml per litre of water. A necessary change of water is indicated by fading of the blue colouration.

3 Packing units:

- Order No. 1910 for 1 bottle / Contents 200 ml
- Order No. 1911 for 3 bottles / Contents 3 x 200 ml
- Order No. 1912 for 6 bottles / Contents 6 x 200 ml

Summary of Laboratory Products



■ Chest Freezers Page 3



■ Upright Freezers Page 3

■ Water Baths Page 21

■ Tissue Float Bath Page 31



■ Shaking Water Baths Page 33

■ THERMOLAB® Page 38

■ Incubators Page 41

■ Shaking Incubators Page 44



■ Hybridisation Incubator Page 48

■ Mini Incubator Page 50

■ Tube Roller Incubator Page 50



■ Shakers Page 53

■ Test Tube Rotator Page 64

■ Rotating Shaker Page 65

■ Water Stills Page 71



Would you like to find out more details about our range of products?

Phone: ++ 49 - 5139 99 58 - 0

Fax: ++ 49 - 5139 99 58 21

E-Mail: info@GFL.de

Internet: www.GFL.de

Shaking Incubators Mini Incubators Hybridisation Incubator

GFL®



■ State-of-the-art technique and first-class materials secure a top position in the market for our internationally renowned Incubators.



Quality built on Tradition

Users in research labs, standard and special labs for medicine, science and industry throughout the world have been profiting from the precision and dependability of our products for 45 years, all of which comply with valid European standards and bear the CE mark.

In the future, the success of a product spectrum of laboratory devices that meet the toughest demands on material, functioning and design will continue to be ensured by experience of every-day use in detail, ongoing technical advances and an excellent quality approach.

The phrase „Quality built on Tradition“ encompasses more than just the sum of impressive product innovations. It is also an expression of our corporate policy, which includes a high degree of ready-and-waiting service as our primary customer-friendly service goal.

This applies to all of the GFL laboratory products that are produced exclusively at our plant in Germany - Deep Freezers, Shakers, Shaking Water Baths, Water Baths, Water Stills or Incubators alike.



Secure future

A vested quality demand in accordance with international standards is documented for all GFL laboratory products with the certification to DIN EN ISO 9001:2008, promoting more trust in the permanent high quality level of our products.

In addition to the continuous optimisation of ongoing production processes, the ISO obligation also calls for the commitment to quality awareness of our employees and the continuous development and rapid implementation of preventive measures to ensure quality assurance at a high level.

GFL - PC remote control



GFL Shaking Incubators models 3031 - 3033 operate with state-of-the-art microprocessor technique and dispose of an interface module for comfortable remote control of measuring, controlling and regulating tasks via PC.

The built-in serial interface RS 232 ensures smooth and easy data transfer, at the same time providing compatibility of our Shaking Incubators

with the PC software programme labworldsoft®.

Among other features, this comprehensive software programme enables independent PC control and data analysis of up to 64 laboratory appliances. Set and actual values are available as output signals.

Data input is made online and can be displayed either graphically or numerically. Complete measurement configurations can be memorized with all necessary parameters for optimum

reproducibility. Ready-to-use measuring procedures for various applications are pre-configured and easily retrievable.

System requirements:

Hardware

- Pentium 90 with at least 16 MB RAM, 8 MB free mainboard memory, mouse
- VGA display: monochrome with at least 16 grey shades or colour

Software

- Windows 95/98/2000/NT/ME/XP...







The most progressive technique and first-class quality materials are used to secure GFL Incubators a top position in the market. Three different product ranges cover the most versatile applications in laboratories: Shaking Incubators (3), Mini Incubators (2) and a Hybridisation Incubator.

Our Incubators bear the CE sign, are maintenance-free and can be equipped with numerous accessories. Their stable and durable mechanism ensures an especially silent operation and reliability in continuous mode. The microprocessor-controlled electronics regulates the gentle start-up and exact shaking frequency.

If not expressly stated, the accessories shown in the product pictures in this brochure are not part of the standard scope of supply. The right of constructional modifications remains reserved. Special makes are possible.

Contents

Product No	Motion	Load	Page	Accessories / Page
3031	 Shaking Incubator with orbital motion	12 kg	44/45	46
3032	 Shaking Incubator with orbital motion	12 kg	44/45	47
3033	 Shaking Incubator with orbital motion	20 kg	44/45	47
7601	 Hybridisation Incubator	5 kg	48	49
4010	Mini Incubator	5 kg	50/51	–
4020	 Mini Tube Roller Incubator	3 kg	50/51	51

Shaking Incubators

Heavy-duty Specialists

In every-day laboratory use GFL Shaking Incubators are renowned as being extremely reliable and suitable for heavy-duty use. Model 3031, with lift-up acrylic glass cover, is made of an outer housing of heavy-duty ABS and powder-coated, electrolytically galvanised sheet steel.

The shaking platform, made of aluminium, disposes of four plastic pins to accept a shaking tray or a universal mount (accessories).

The outer housings of models 3032 and 3033 are made of powder-coated, electrolytically galvanised sheet steel. Interior cabinet, the insides of the doors and the shaking platform are made of stainless steel.

The frame, permitting the use of two shaking trays, is part of the standard scope of supply. Shaking trays are accessories. A fluorescent lamp for interior illumination is separated from the cabinet by a diffusing screen.



3031

Technical Data

Shaking frequency: 10 - max. 250 rpm

Shaking amplitude: 30 mm

Load: up to 12 kg max.

Volume / capacity:
approx. 46 l / 1 shaking tray

Interior dimensions (W x D x H):
450 x 450 x 280 mm

Exterior dimensions (W x D x H):
525 x 665 x 570 mm

Electrical connection:
230 V / 50...60 Hz / 0.8 kW *
* Other voltages on request

Net / gross weight: 38.5 kg / 50 kg

Packing volume (cardboard box):
approx. 0.51 m³

Order No. 3031

Specifications and Features

- ▶ Fast and exact temperature setting, exact reproducibility of set values, such as temperature, shaking frequency and incubation time, due to microprocessor-technique.
- ▶ Optimum temperature distribution throughout the cabinet interior.
- ▶ Serial cooling coil for applications below ambient temperature.
- ▶ Electronic monitoring of the temperature regulators triggers visual and acoustic alarms in case of fault. The heating is switched off, the cause of the fault is shown on the LED display.
- ▶ Silent and robust shaking mechanism with gentle start-up and even orbital motion, independent of load, set shaking frequency and incubation time.
- ▶ Microprocessor-controlled timer for continuous display of the current remaining running time of the incubation period, with acoustic expiry signal.
- ▶ Soft-touch keys with clear symbols. Adjustable over- and under-temperature cut-out up to max 9.9 °C.

Applications

Specialised in gentle mixing as well as vigorous shaking, GFL Shaking Incubators are used for applications that require exactly reproducible orbital motions and temperatures of up to +70 °C (temperature constancy ± 0.2 °C, temporal).

They are preferred by standard and research laboratories for incubations, fermentations, homogenisations, chemical and biochemical reactions, enzyme and tissue studies, as well as for cultivating bacteria cultures.

Further technical data of models 3031 / 3032 / 3033

Temperature range:	from 8 °C above ambient temperature to +70 °C, serial cooling coil for operation below ambient temperature to connect to the water mains or to an external recirculating chiller
Temperature range (Operation with cooling coil):	+20 °C to +70 °C ** ** dependent on cooling media and ambient temperature
Temperature constancy (temporal):	±0.2 °C
Temperature regulation:	microprocessor-controlled, PID type
Temperature setting and display:	digital - LED, in 0.1 °C increments
Over-temperature cut-out:	electronical / dependent on the set value, to protect the test substances, and electro-mechanically, to protect the unit
Under-temperature cut-out:	electronical, max. 9.9 °C below set temperature
Shaking motion:	orbital, can be switched on and off
Shaking frequency regulation:	microprocessor-controlled
Shaking frequency display and setting:	digital - LED
Incubation time:	microprocessor-controlled, 1 minute to 999:59 hours
Time display and setting:	digital - LED
Serial interface:	RS 232

3032

Technical Data

Shaking frequency:	10 - max. 250 rpm
Shaking amplitude:	25 mm
Load:	up to 12 kg max.
Volume / capacity:	approx. 45 l / 2 shaking trays, for vessel height of more than 150 mm 1 shaking tray
Interior dimensions (W x D x H):	450 x 300 x 320 mm
Exterior dimensions (W x D x H):	710 x 650 x 710 mm
Electrical connection:	230 V / 50...60 Hz / 0.8 kW * * Other voltages on request
Net / gross weight:	70 kg / 80 kg
Packing volume (cardboard box):	approx. 0.86 m ³

Order No. 3032



3033

Technical Data

Shaking frequency:	10 - max. 250 rpm if only bottom tray is loaded; 10 - max. 200 rpm if both trays are loaded
Shaking amplitude:	25 mm
Load:	up to 20 kg max.
Volume / capacity:	approx. 150 l / 2 shaking trays, for vessel height of more than 180 mm 1 shaking tray
Interior dimensions (W x D x H):	674 x 540 x 430 mm
Exterior dimensions (W x D x H):	930 x 890 x 820 mm
Electrical connection:	230 V / 50...60 Hz / 0.8 kW * * Other voltages on request
Net / gross weight:	135 kg / 270 kg
Packing volume (wooden crate):	approx. 1.74 m ³

Order No. 3033



Accessories



3031



Shaking Tray

made of stainless steel, 450 x 450 mm, with holes to accept clamps for Erlenmeyer flasks, test tube racks and holding frames for test plates.

Order No. 3966

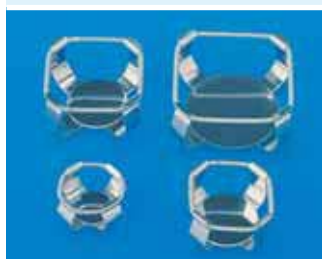

Flask Clamps

made of stainless steel, for Erlenmeyer flasks, to be screwed onto shaking tray 3966, complete with fixing material.

- Order No. 3983** for 25 ml flasks (79*)
- Order No. 3984** for 50 ml flasks (49*)
- Order No. 3985** for 100 ml flasks (36*)
- Order No. 3986** for 200 ml flasks (22*)
- Order No. 3987** for 250-300 ml flasks (16*)
- Order No. 3988** for 500 ml flasks (12*)
- Order No. 3989** for 1000 ml flasks (9*)

Other clamps on request.

* Maximum quantity of flask clamps per shaking tray

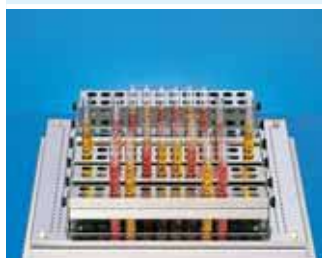

Test Tube Rack

made of stainless steel, for test tubes, perforated part can be tilted by 90°, with clamping springs for secure hold and silent shaking of the tubes, to be screwed onto shaking tray 3966.

Order No. 3953

for max. 24 tubes: 12-17 mm Ø

capacity of the shaking tray: 6 test tube racks



Holding Frame

made of stainless steel, for attachment of a test plate, for screwing on to shaking tray 3966, complete with attachment materials

Order No. 3910

Capacity of shaking tray: 6 test plates

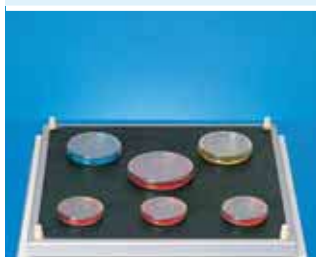

Non-slip Rubber Mat

for the shaking platform, 420 x 420 mm, for slow moving of e.g. of nutrients in Petri dishes.

Order No. 3965



Universal Mount

for secure fixing of different shaking objects between the six rubber-coated bars.

Order No. 3967



3032



3033



Shaking Tray
made of stainless steel, 450 x 300 mm, with holes to accept clamps for Erlenmeyer flasks, test tube racks and holding frames for test plates.

Order No. 3970
Capacity of the frame: 2 shaking trays



Shaking Tray
made of anodised aluminium, 670 x 537 mm, with 99 holes to accept clamps for Erlenmeyer flasks, test tube racks and holding frames for test plates.

Order No. 3980
Capacity of the frame: 2 shaking trays

3032 and 3033

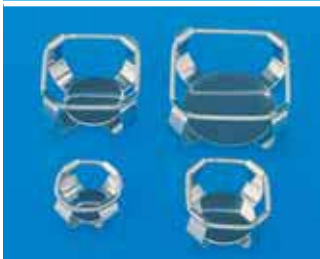

Flask Clamps
made of stainless steel, for Erlenmeyer flasks, to be screwed onto shaking trays 3970 and 3980, complete with fixing material.

		3032	3033
		Tray 3970	Tray 3980
Order No. 3983 for	25 ml flasks	(52)	(99)
Order No. 3984 for	50 ml flasks	(33)	(99)
Order No. 3985 for	100 ml flasks	(22)	(50)
Order No. 3986 for	200 ml flasks	(15)	(26)
Order No. 3987 for	250-300 ml flasks	(13)*	(26)
Order No. 3988 for	500 ml flasks	(10)*	(26)
Order No. 3989 for	1000 ml flasks	(6)*	(12)*
Order No. 3990 for	2000 ml flasks	(3)*	(9)*

Other clamps on request.

Quantities stated: Maximum quantity of flask clamps per shaking tray
* 3032 (Shaking tray 3970): From clamps 300 ml only 1 tray applicable
* 3033 (Shaking tray 3980): From clamps 1000 ml only 1 tray applicable



Test Tube Rack
made of stainless steel, for test tubes, perforated part can be tilted by 90°, with clamping springs for secure hold and silent shaking of the tubes, to be screwed onto shaking trays 3970 and 3980.

Order No. 3953
for max. 24 tubes: 12 - 17 mm Ø
capacity of shaking tray 3970 (3032): 3 test tube racks
capacity of shaking tray 3980 (3033): 9 test tube racks



Holding Frame
made of stainless steel, for attachment of a test plate, for screwing on to shaking trays 3970 and 3980, complete with attachment materials

Order No. 3910
Capacity of shaking tray 3970 (3032): 6 test plates
Capacity of shaking tray 3980 (3033): 15 test plates

Hybridisation Incubator

7601

Technical data

Temperature regulation:
microprocessor-controlled

Temperature range:
approx. 8 °C above ambient to +99.9 °C

Temperature constancy (temporal): ±0.5 °C

Temperature setting and display:
digital - LED, in 0.1 °C increments

Over-temperature cut-out:
electronical / dependent on the set value,
with visual alarm at 4 °C above the set
temperature, and electro-mechanical > 130 °C

Rotations of the rotating rack:
10 per minute, fixed

Cabinet illumination:
2 lamps at 15 Watt each

Interior dimensions (W x D x H):
400 x 330 x 380 mm

Exterior dimensions (W x D x H):
585 x 630 x 650 mm

Electrical connection:
230 V / 50...60 Hz / 0.55 kW *
* Other voltages on request

Net / gross weight: 45 kg / 54 kg

Packing volume (cardboard box):
approx. 0.51 m³

■ **Order No. 7601**

■ Ideally suited for special cases

The GFL Hybridisation Incubator 7601 is a specialist for individual cases. The small quantity of hybridisation liquid that is required enables the user to work with high concentrations of probes or antibodies.

Other applications are also possible. Instead of the rotating rack, the Incubator's interior can be equipped with up to five non-tilt and pull-out trays (accessories).

The rotating rack to accept the hybridisation vessels is driven by a geared motor via a sliding clutch. It is easily removable and can be loaded outside the Incubator.



Specifications and Features

- ▶ The ventilator ensures optimum temperature distribution throughout the cabinet interior.
- ▶ Electronical monitoring of the temperature controller triggers a visual alarm in case of fault, i.e. if the set value is exceeded by 4 °C. The heating is switched off, the cause of the fault is shown on the LED display
- ▶ Thermostatic over-temperature cut-out to protect the heating element.
- ▶ High resolutions of the detections and even results due to the constancy of 10 rpm.
- ▶ Soft-touch keys with clear symbols. Protection against unintended alterations by two-finger-operation.
- ▶ Clear view of the interior cabinet through a large 16 mm thick heat-insulating acrylic glass window. Keys to switch on two cabinet lamps.
- ▶ The interior parts of the unit, such as cabinet walls, air baffle plate, interior door frame, rotating rack and the removable drip tray under the rotating rack are made of stainless steel, the robust housing is made of electrolytically galvanised sheet steel.



7601

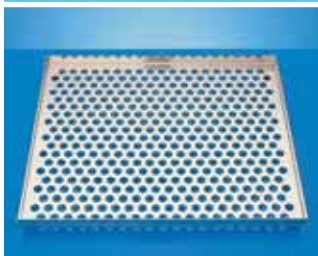

Order No. 7914

Perforated Tray

made of stainless steel, can only be used instead of the rotating rack; max. five trays.

Applications

In every-day laboratory use our Hybridisation Incubator is successfully employed as an ideal appliance for exact hybridisations of DNA and RNA probes with nucleic acid on filter paper (Southern / Northern Blots) and for incubations of protein blots with antibodies (Western Blots).



Clip Wheel

made of stainless steel, with holes for spring clips. Two more clip wheels can be inserted to double the capacity of shorter vessels. Two clip wheels are required for safe and horizontal fixing.

Order No. 7940

Two clip wheels are in the standard scope of supply.



Special Hybridisation Bottles

made of borosilicate glass, plastic screw cap with 0.5 mm bore hole in the middle for pressure compensation (also available without bore holes on request).

Order No. 7943 for Ø 32 mm, 273 mm length (16*)

Order No. 7944 for Ø 38 mm, 273 mm length (8*)

Order No. 7945 for Ø 51 mm, 273 mm length (8*)

* Capacity of the rotating rack (quantity of bottles)

Four bottles 7945 are in the standard scope of supply.



Spring Clips

to fix the hybridisation bottles on the clip wheels. Two spring clips are required for each bottle. The required fixing material is supplied with each clip.

Order No. 7935 for Ø 32 mm, (16/32)*

Order No. 7936 for Ø 38 mm, (8/16)*

Order No. 7937 for Ø 51 mm, (8/16)*

* maximum quantity of clips per clip wheel / required quantity of clips

Eight spring clips 7937 are in the standard scope of supply.

Mini/Tube Roller Incubator

■ Proven and space-saving

In standard and research laboratories, our **Mini Incubator 4010** and the **Tube Roller Incubator 4020** have meanwhile become indispensable. Due to their compact build, both models require only little space and are, therefore, very well suited for versatile applications directly on the workbench. Furthermore, their lift-up, see-through acrylic glass covers permit a clear view of the cultures in the interior cabinet.



4020

Technical Data

Temperature regulation:
microprocessor-controlled

Temperature range:
approx. 8 °C above ambient to +60 °C

Temperature constancy (temporal): ± 0.2 °C

Temperature setting and display:
digital - LED, in 0.1 °C increments

Over-temperature cut-out:
electronical / dependent on the set value,
with visual alarm at 4 °C above the set
value, and electro-mechanical > 130 °C

Volume: approx. 10 l

Motion: rotating

Frequency: 12 rpm fixed

Maximum load: 3 kg

Interior dimensions (W x D x H):
230 x 300 x 140 mm

Exterior dimensions (W x D x H):
280 x 510 x 280 mm

Electrical connection:
230 V / 50...60 Hz / 0.3 kW *

* Other voltages on request

Net / gross weight: 11.8 kg / 13.7 kg

Packing volume (cardboard box):
approx. 0.11 m³

■ Order No. 4020

4010

Technical Data

Temperature regulation:
microprocessor-controlled

Temperature range:
approx. 8 °C above ambient to +60 °C

Temperature constancy (temporal): ± 0.2 °C

Temperature setting and display:
digital - LED, in 0.1 °C increments

Over-temperature cut-out:
electronical / dependent on the set value,
with visual alarm at 4 °C above the set
value, and electro-mechanical > 130 °C

Volume: 12 l

Maximum load: 5 kg

Interior dimensions (W x D x H)
230 x 310 x 170 mm

Exterior dimensions (W x D x H):
280 x 510 x 280 mm

Electrical connection:
230 V / 50...60 Hz / 0.3 kW *

* Other voltages on request

Net / gross weight: 9.9 kg / 11.8 kg

Packing volume (cardboard box):
approx. 0.11 m³

■ Order No. 4010



Mini Tube Roller Incubator 4020

disposes of a removable bottle rotating device, consisting of four parallel rotating axes each with two rubber rollers that can be moved along the axle.

Hybridisation bottles with \varnothing 32 mm to \varnothing 76 mm can be placed individually or in pairs (even with different diameters) between the rubber rollers; the use of two roller bottles for cell cultures with \varnothing 110 mm and 285 mm length is possible.

To place bottles of different diameters, the outer axes can be placed into pre-fabricated seats without the use of tools.



4020



Special Hybridisation Bottles

made of borosilicate glass, to place between the rubber rollers. Plastic screw cap with 0.5 mm bore hole in the middle for pressure compensation (also available without bore holes on request).

Order No. 7943 for \varnothing 32 mm, 273 mm length

Order No. 7944 for \varnothing 38 mm, 273 mm length

Order No. 7945 for \varnothing 51 mm, 273 mm length

Specifications and Features

- ▶ The ventilator ensures optimum temperature distribution throughout the cabinet interior.
- ▶ Electronical monitoring of the temperature controller triggers a visual alarm in case of fault, i.e. if the set value is exceeded by 4 °C. The heating is switched off, the cause of the fault is shown on the LED display.
- ▶ Thermostatic over-temperature cut-out to protect the heating element.
- ▶ Soft-touch keys with clear symbols. Protection against unintended alterations by two-finger-operation.
- ▶ Microprocessor-controlled temperature regulation ensures fast reaching of set temperatures and high temperature constancy. Exact reproducibility of the set value by fast and exact temperature setting.
- ▶ Perforated tray, bottom tray (4010) and removable flask rotating device (4020) are made of stainless steel.

Applications

The Mini Incubator is very well suited for incubations that require exactly reproducible temperatures, also for tempering, warming and drying of samples.

The Mini Tube Roller Incubator is universally applicable for incubations and hybridisations. It is equipped with a variable, removable flask rotating device, and provides even results and high resolutions of the detections even when in continuous use due to its constant frequency of 12 rpm.

Summary of Laboratory Products



■ Chest Freezers Page 3



■ Upright Freezers Page 3

■ Water Baths Page 21

■ Tissue Float Bath Page 31



■ Shaking Water Baths Page 33

■ THERMOLAB® Page 38

■ Incubators Page 41



■ Shaking Incubators Page 44

■ Hybridisation Incubator Page 48

■ Mini Incubator Page 50



■ Tube Roller Incubator Page 50

■ Shakers Page 53



■ Test Tube Rotator Page 64

■ Rotating Shaker Page 65



■ Water Stills Page 71



Would you like to find out more details about our range of products?

Phone: ++ 49 - 5139 99 58 - 0

Fax: ++ 49 - 5139 99 58 21

E-Mail: info@GFL.de

Internet: www.GFL.de

Shakers

GFL[®]



- For gentle motion, vigorous mixing or intensive shaking - you can choose between 15 quality products and five different types of shaking motion.



Quality built on Tradition

Users in research labs, standard and special labs for medicine, science and industry throughout the world have been profiting from the precision and dependability of our products for 45 years, all of which comply with valid European standards and bear the CE mark.

In the future, the success of a product spectrum of laboratory devices that meet the toughest demands on material, functioning and design will continue to be ensured by experience of every-day use in detail, ongoing technical advances and an excellent quality approach.

The phrase „Quality built on Tradition“ encompasses more than just the sum of impressive product innovations. It is also an expression of our corporate policy, which includes a high degree of ready-and-waiting service as our primary customer-friendly service goal.

This applies to all of the GFL laboratory products that are produced exclusively at our plant in Germany - Deep Freezers, Shaking Water Baths, Water Baths, Incubators, Water Stills or Shakers alike.



Secure future

A vested quality demand in accordance with international standards is documented for all GFL laboratory products with the certification to DIN EN ISO 9001:2008, promoting more trust in the permanent high quality level of our products.

In addition to the continuous optimisation of ongoing production processes, the ISO obligation also calls for the commitment to quality awareness of our employees and the continuous development and rapid implementation of preventive measures to ensure quality assurance at a high level.

GFL Unit Control by PC



GFL Shakers with the model designation 3012, 3014, 3017, 3018 and 3020 are equipped both with microprocessor technique and with an interface module for convenient data control by I&C tasks via PC.

Trouble-free data transfer is realised via the built-in RS 232 port, making all of the units cited above compatible simultaneously, for example, to the PC software labworldsoft®.

Using this software, up to 64 lab devices, among other things, can be controlled independently of one another from a PC and all data evaluated. Specified and actual values are available as output signals.

Data acquisition is effected online and can be presented either graphically or numerically. Complete instrument configurations can be stored with all of their current parameters for optimum reproducibility. This allows you to call

up pre-configured instrumentation flow diagrams that are immediately ready for operation for the most varying of tasks.

System requirements:

Hardware

- Pentium 90 with at least 16 MB RAM, 8 MB free disk space, mouse
- VGA display; monochrome display with at least 16 grey levels, or colour

Software

- Windows 95/98/2000/NT/ME/XP...



There are 15 different model variants of GFL Shakers with five types of motion. All of these models have the CE mark, are low-maintenance and have the German TUV seal for „approved safety“ (GS) required by the German device safety legislation.

All of the device models are controlled either digitally or by analogue means. Their stable, low-wear drive mechanisms ensure a particularly smooth working motion and dependable, long-term service. The electronic system controls the soft start-up of the devices.

GFL Shakers are marked by their capability to easily accommodate and fasten to

the shaking platform almost all shapes of vessels used in standard laboratory applications, thanks to the variety of accessories available for the devices.

The accessories shown in the product illustrations in this catalogue are not part of the standard scope of supply for the devices. All designs are subject to change. Special devices available on request.

Contents

Product-No.	Type of motion	Max. load	Page	Accessories / Page
3005	Orbital motion	8 kg	56	66
3006	Reciprocating motion	8 kg	57	66
3011 / 3012	Orbital rocking motion	15 kg	58	67
3013 / 3014	Rocking motion	15 kg	59	67
3015 / 3017	Orbital motion	15 kg	60	68
3016 / 3018	Reciprocating motion	15 kg	61	68
3019 / 3020	Orbital motion	30 kg	62	69
3023	Vibration Shaker with orbital motion	1.2 kg	63	—
3025	Test Tube Rotator with rotating motion	max. 24 tubes	64	—
3040	Rotating Shaker	20 kg	65	—

3005

Power in a small package

Its use in everyday applications has already earned this model the motto „Great performance in a small package“. A powerful, quiet, space-saving model, versatile, either for gentle movement of liquids or vigorous mixing of the most varying materials. This unit is maintenance-free, carries the GS safety approval and comes with the CE mark.



3005 Analogue Orbital Shaker with Universal Mount 3952

Features

- ▶ compact, low-wear counterbalanced drive mechanism, ensuring high stability and dependability for continuous operation
- ▶ housing made of high impact strength polystyrene, off-white varnish. The base plate is made of electrolytically galvanised, powder-coated sheet steel, the shaking platform of anodised aluminium, equipped with four plastic pins for secure attachment of accessory equipment
- ▶ an a.c. motor with overload protection drives the unit
- ▶ clearly laid out control panel for easy operation

Technical Data

Overall dimensions (W x D x H):
380 x 510 x 140 mm

Moving platform: 330 x 330 mm

Load: max. 8 kg

Shaking motion: orbital

Timer: up to 60 minutes, or continuous operation

Shaking amplitude: 10 mm

Shaking frequency: 20 - 500 rpm

Electrical connection:

230 V* 50...60 Hz, 65 W

* Other voltages on request!

Net/gross weight: 10/12 kg

Packing volume (cardboard box): 0.1 m³

▶ **Order No. 3005**

- ▶ electronic speed control, stepless, with gentle start-up
- ▶ constant speed during continuous operation, independent of load

Applications

This compact Orbital Shaker proves its performance capability in daily use in biology and microbiology laboratories and in diagnostic test reactions.

Also used in laboratories, incubation rooms and moderating rooms at ambient temperatures between +10 °C and +50 °C.

Space-saving and versatile

What sets this robust, space-saving compact Shaker apart from the 3005 Shaker is its shaking motion. Its impressive features are both its gentle back-and-forth motion and its intensive shaking of liquids, especially in separating funnels. This unit is maintenance-free, carries the GS safety approval and comes with the CE mark.

3006



3006 Analogue Reciprocating Shaker with Tray 3950 and Clamps for separating funnels 3955 - 3959

Technical Data

Overall dimensions (W x D x H):
380 x 510 x 140 mm

Moving platform: 330 x 330 mm

Load: max. 8 kg

Shaking motion: reciprocating
(back and forth)

Timer: up to 60 minutes, or continuous
operation

Shaking amplitude: 20 mm

Shaking frequency: 20 - 300 rpm

Electrical connection:

230 V* 50...60 Hz, 65 W

* Other voltages on request!

Net/gross weight 10/12 kg

Packing volume (cardboard box): 0.1 m³

Order No. 3006

Features

- ▶ compact, low-wear counterbalanced drive mechanism, ensuring high stability and dependability for continuous operation
- ▶ housing made of high impact strength polystyrene, off-white varnish. The base plate is made of electrolytically galvanised, powder-coated sheet steel, the shaking platform of anodised aluminium, equipped with four plastic pins for secure attachment of accessory equipment
- ▶ an a.c. motor with overload protection drives the unit
- ▶ clearly laid out control panel for easy operation

- ▶ electronic speed control, stepless, with gentle start-up
- ▶ constant speed during continuous operation, independent of load

Applications

This Shaker can be used in medical diagnostics or analysis, as well as for growing micro-organisms, cell and tissue cultures.

This unit is used particularly in laboratories, incubation rooms and moderating rooms at ambient temperatures between +10 °C and +50 °C.

3011 / 3012

Gentle and quiet

Gentle and uniform rocking motion make this quiet unit stand out in every-day use. Both of these units are maintenance-free, carry the GS safety approval and come with the CE mark.



3011 Analogue Orbital Rocking Motion Shaker with Non-slip Mat 3965

Technical Data

Overall dimensions (W x D x H):
510 x 625 x 168 mm

Moving platform: 450 x 450 mm

Load: max.15 kg

Shaking motion: three-dimensional orbital rocking

Timer:

3011 / up to 60 minutes, or continuous operation

3012 / 1 min. - 99:59 hours, or continuous operation

Shaking amplitude: 3 degrees

Shaking frequency: 2 - 50 rpm

Electrical connection: 230 V*

* Other voltages on request!

3011 / 50...60 Hz, 90 W

3012 / 50 or 60 Hz**, 90 W

** Please indicate when ordering!

Net/gross weight: 18/22 kg

Packing volume (cardboard box): 0.19 m³

■ **Order No. 3011**

■ **Order No. 3012**
with RS 232 port

Features

- ▶ compact, low-wear counterbalanced drive mechanism, ensuring dependability for continuous operation with three-dimensional motion
- ▶ housing made of high impact strength polystyrene, off-white varnish. The base plate is made of electrolytically galvanised, powder-coated sheet steel, the shaking platform of anodised aluminium, equipped with four plastic pins for secure attachment of accessory equipment
- ▶ an a.c. motor with overload protection drives the unit
- ▶ 3011 - clearly laid-out control panel for easy operation
- ▶ 3012 - speed and remaining time indicated by two LC displays

- ▶ 3011 - electronic speed control, stepless, gentle start-up
- ▶ 3012 - microprocessor-controlled, adjustable in steps of 0.5 rpm, gentle start-up
- ▶ constant speed during continuous operation, independent of load

Applications

In AIDS research, for diagnostic tests with test plates, or for growing cell cultures and micro-organisms this unit has become indispensable.

Also well-suited for use in laboratories, incubation rooms and moderating rooms at ambient temperatures between +10 °C and +50 °C.

Dependable and long-lasting

These versatile Shakers use their slow and uniform rocking motion to create reproducible growth and processing conditions at low speeds for cell cultures and other media.

This permits ideal rinsing and tumbling of the samples. Both of these units are maintenance-free, carry the GS safety approval and come with the CE mark.



Technical Data

Overall dimensions (W x D x H):
510 x 625 x 168 mm

Moving platform: 450 x 450 mm

Load: max.15 kg

Shaking motion: rocking

Timer:

3013 / up to 60 minutes, or continuous operation

3014 / 1 min. - 99:59 hours, or continuous operation

Rocking amplitude: 3 degrees

Rocking frequency: 2 - 50 rpm

Electrical connection: 230 V*

* Other voltages on request!

3013 / 50...60 Hz, 90 W

3014 / 50 or 60 Hz**, 90 W

** Please indicate when ordering!

Net/gross weight: 18/21 kg

Packing volume (cardboard box): 0.19 m³

■ Order No. 3013

■ Order No. 3014
with RS 232 port



3013 Analogue Rocking Motion Shaker with Platform Frame 3968

Features

- ▶ compact, low-wear counterbalanced drive mechanism, ensuring dependability for slow rocking motion
- ▶ housing made of high impact strength polystyrene, off-white varnish. The base plate is made of electrolytically galvanised, powder-coated sheet steel, the shaking platform of anodised aluminium, equipped with four plastic pins for secure attachment of accessory equipment
- ▶ an a.c. motor with overload protection drives the unit
- ▶ 3013 - clearly laid-out control panel for easy operation
3014 - speed and remaining time indicated by two LC displays

- ▶ 3013 - electronic speed control, stepless, gentle start-up
3014 - microprocessor-controlled, adjustable in steps of 0.5 rpm, gentle start-up
- ▶ constant speed during continuous operation, independent of load

Applications

This model has proven itself through reliable and perfect work, also for continuous operation, and is always called upon when the best possible supply of parallel cultures and cell lines is required, or for staining or discoloration of gels.

Both of these units are well-suited for use in laboratories, incubation rooms and moderating rooms at ambient temperatures between +10 °C and +50 °C.

3015 / 3017

■ Universal and untiring

A silent operating and universally applicable Orbital Shaker that exhibits its untiring strength in particular for gentle motion and vigorous shaking of liquids. Both of these units are maintenance-free, carry the GS safety approval and come with the CE mark.



Technical Data

Overall dimensions (W x D x H):
510 x 625 x 142 mm

Moving platform: 450 x 450 mm

Load: max. 15 kg

Shaking motion: orbital

Timer:

3015 / up to 60 minutes, or continuous operation

3017 / 1 min. - 99:59 hours, or continuous operation

Shaking amplitude: 30 mm

Shaking frequency: 20 - 300 rpm

Electrical connection: 230 V*

* Other voltages on request!

3015 / 50...60 Hz, 65 W

3017 / 50 or 60 Hz**, 65 W

** Please indicate when ordering!

Net/gross weight: 18/22 kg

Packing volume (cardboard box): 0.19 m³

■ Order No. 3015

■ Order No. 3017
with RS 232 port



Features

▶ compact, low-wear counterbalanced drive mechanism, ensuring high stability and dependability for orbital shaking motion

▶ housing made of high impact strength polystyrene, off-white varnish. The base plate is made of electrolytically galvanised, powder-coated sheet steel, the shaking platform of anodised aluminium, equipped with four plastic pins for secure attachment of accessory equipment

▶ an a.c motor with overload protection drives the unit

▶ 3015 - clearly laid-out control panel for easy operation

3017 - speed and remaining time indicated by two LC displays

▶ 3015 - electronic speed control, stepless, gentle start-up

3017 - microprocessor-controlled, adjustable in steps of 1.0 rpm, gentle start-up

▶ constant speed during continuous operation, independent of load

Applications

What counts when growing micro-organisms, cell and tissue cultures is a „reliable colleague“ - an indispensable ingredient for successful work in bio-chemistry, microbiology, biotechnology, bacteriology and virology.

Both of these units are particularly well-suited for use in laboratories, incubation rooms and moderating rooms in ambient temperatures between +10 °C and +50 °C.



3015 Analogue Orbital Shaker with Tray 3966 and Clamps for Erlenmeyer flasks 3983 - 3990

3016 / 3018

■ Robust and variable

Versatile, powerful and exceptionally quiet - those are the descriptive qualities of this robust Shaker with reciprocating (back-and-forth) motion. Use of this device is recommended for vigorous and intensive shaking of clamped lying flasks, mixing flasks or separating funnels in continuous operation. Both of these units are maintenance-free, carry the GS safety approval and come with the CE mark.



Technical Data

Overall dimensions (W x D x H):
510 x 625 x 145 mm

Moving platform: 450 x 450 mm

Load: max.15 kg

Shaking motion: reciprocating

Timer:

3016 / up to 60 minutes, or continuous operation

3018 / 1 min. - 99:59 hours, or continuous operation

Shaking amplitude: 30 mm

Shaking frequency: 20 - 300 rpm

Electrical connection: 230 V*

* Other voltages on request!

3016 / 50...60 Hz, 65 W

3018 / 50 or 60 Hz**, 65 W

** Please indicate when ordering!

Net/gross weight: 18/22 kg

Packing volume (cardboard box): 0.19 m³

■ Order No. 3016

■ Order No. 3018

with RS 232 port



3016 Analogue Back-and-forth Shaker with Tray 3966 and Test Tube Racks 3953

Features

- ▶ compact, low-wear counterbalanced drive mechanism, ensuring high stability and dependability for reciprocal shaking motion
- ▶ housing made of high impact strength polystyrene, off-white varnish. The base plate is made of electrolytically galvanised, powder-coated sheet steel, the shaking platform of anodised aluminium, equipped with four plastic pins for secure attachment of accessory equipment
- ▶ an a.c. motor with overload protection drives the unit
- ▶ 3016 - clearly laid-out control panel for easy operation
3018 - speed and remaining time indicated by two LC displays

- ▶ 3016 - electronic speed control, stepless, gentle start-up
3018 - microprocessor-controlled, adjustable in steps of 1.0 rpm, gentle start-up
- ▶ constant speed during continuous operation, independent of load

Applications

The producers of suspensions and emulsions know this shaker well. The shaking platform's jerky back-and-forth motion creates high turbulence, thus thoroughly mixing the media. This is a vital prerequisite, for example, in medical diagnostics, or in foodstuffs or environmental analyses.

Both of these units are well-suited for use in laboratories, incubation rooms and moderating rooms in ambient temperatures between +10 °C and +50 °C.

3019 / 3020

Technical Data

Overall dimensions (W x D x H):
745 x 730 x 135 mm

Moving platform: 676 x 540 mm

Load: max. 30 kg

Shaking motion: orbital

Timer:

3019 / up to 60 minutes, or continuous operation

3020 / 1 min. - 99:59 hours, or continuous operation

Shaking amplitude: 32 mm

Shaking frequency: 20 - 250 rpm

when the rack frame is used: 20 - 200 rpm

Electrical connection: 230 V*

* Other voltages on request!

3019 / 50...60 Hz, 90 W

3020 / 50 or 60 Hz**, 90 W

** Please indicate when ordering!

Net/gross weight: 34/40 kg

Packing volume (cardboard box): 0.35 m³

■ Order No. 3019

■ Order No. 3020

with RS 232 port

■ Indispensable and powerful

A dependable, long-life Orbital Shaker with a large shaking tray for accommodating heavier loads. A universally applicable, quiet unit, indispensable in the growing of micro-organisms, cell and tissue cultures.

This unit is well-suited for gentle motion or vigorous mixing of the most varying liquids, even in continuous operation, thanks to its useful shaking amplitude and the option of adjusting its speed. Both of these units are maintenance-free, carry the GS safety approval and come with the CE mark.



3019 Analogue Orbital Shaker with Rack Frame 3981, Trays 3980 (2), Test Tube Racks 3953 and Clamps for Erlenmeyer flasks 3983 - 3990

Features

- ▶ compact, low-wear counterbalanced drive mechanism, ensuring high stability and dependability
- ▶ housing made of high impact strength polystyrene, off-white varnish. The base plate and the

shaking platform are made of electrolytically galvanised, powder-coated sheet steel. The shaking platform is equipped with four support rods with screw-type clamps for secure attachment of accessory equipment

- ▶ a special rubber pad ensures a non-slip grip of objects on the shaking tray
- ▶ an a.c. motor with overload protection drives the unit
- ▶ 3019 - clearly laid-out control panel for easy operation
3020 - speed and remaining time indicated by two LC displays
- ▶ 3019 - electronic speed control, stepless, gentle start-up
3020 - microprocessor-controlled, adjustable in steps of 1.0 rpm, gentle start-up
- ▶ constant speed during continuous operation, independent of load

Applications

Impressive references. For this powerful orbital shaker leaves a lasting impression everywhere it has been used, for example, for analytical or diagnostic applications in the pharmaceutical industry, chemistry, biology, or in plant breeding or nutritional applications.

Both of these units are well-suited for use in laboratories, incubation rooms and moderating rooms in ambient temperatures between +10 °C and +50 °C.



Fast and efficient

This Shaker's high speed and its low shaking amplitude guarantee the best possible mixing, even in the smallest test flasks.

The basic equipment for this vibration shaker with orbital motion includes a frame holder for up to six test plates. This unit is maintenance-free, carries the GS safety approval and comes with the CE mark.

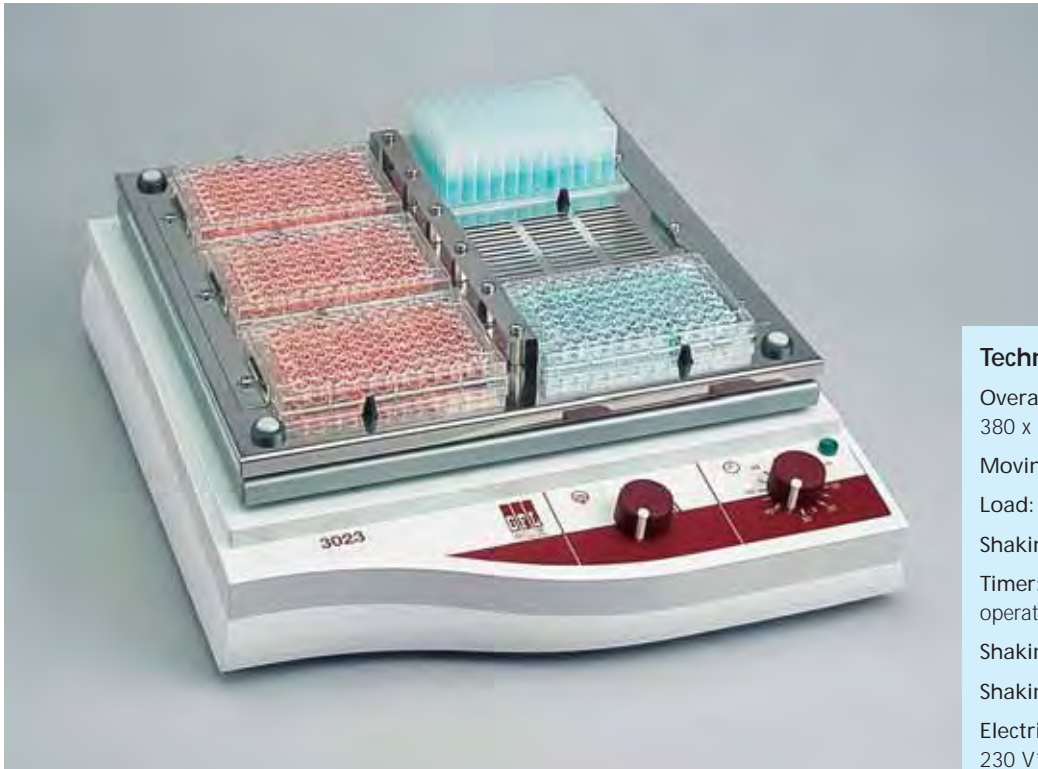

Technical Data

Overall dimensions (W x D x H):
380 x 510 x 125 mm

Moving platform: 330 x 330 mm

Load: max.1.2 kg

Shaking motion: orbital / vibrating

Timer: up to 60 minutes, or continuous operation

Shaking amplitude: 3 mm

Shaking frequency: 100 - 1450 rpm

Electrical connection:

230 V* 50...60 Hz, 65 W

* Other voltages on request!

Net/gross weight: 11/15 kg

Packing volume (cardboard box): 0.1 m³

■ **Order No. 3023**

Features

- ▶ compact, low-wear counterbalanced drive mechanism, ensuring high stability and dependability for continuous operation
- ▶ housing made of high impact strength polystyrene, off-white varnish. The base plate is made of electrolytically galvanised, powder-coated sheet steel, the shaking platform of anodised aluminium, equipped with four plastic pins for secure attachment of accessory equipment (on request) and a frame holder for six test plates (supplied as standard)
- ▶ an a.c. motor with overload protection drives the unit
- ▶ clearly laid out control panel for easy operation

- ▶ electronic speed control, stepless, with gentle start-up
- ▶ constant speed during continuous operation, independent of load

Applications

Reliable, versatile, efficient - the characteristics that make this Shaker so interesting for use in medical diagnostics, biotechnology or microbiology.

This unit is well-suited for use in laboratories, incubation rooms and moderating rooms in ambient temperatures between +10 °C and +50 °C.

3025

Smooth und exact

This Test Tube Rotating Shaker is particularly well-suited for gentle to intensive shaking and mixing of powdered or liquid substances, thanks to its constant, uniform rotating tilting motion. The axle can be removed and can also be loaded outside of the rotator.

This unit is maintenance-free, carries the GS safety approval and comes with the CE mark.



Technical Data

Overall dimensions (W x D x H):
490 x 330 x 220 mm

Revolutions: 6 - 60 rpm

Rotating axle: can accommodate a max. of 24 test tubes, 12-17 mm diameter, tube lengths between 75 und 180 mm

Shaking motion: orbital rotating

Electrical connection:
230 V* 50...60 Hz, 80 W
* Other voltages on request!

Net/gross weight: 10/12 kg

Packing volume (cardboard box): 0.1 m³

■ Order No. 3025

Features

- ▶ compact, low-wear drive mechanism
- ▶ housing made of electrolytically galvanised, powder-coated sheet steel, the axle and collecting trough are made of stainless steel
- ▶ clearly laid out control panel for easy operation
- ▶ electronic speed control, stepless

- ▶ Optionally, the rotator can be equipped without surcharge with an alternative axle, including one set of clamps (on request). Now it is possible to fasten clamps of different sizes, for example for reaction vessels Ø 10 mm or even 50 ml Falcon Tubes Ø 30 mm.

Applications

Smooth and exact motion - that is what this rotator model guarantees when it comes to separating and/or mixing applications.

This unit is well-suited for use in laboratories, incubation rooms and moderating rooms in ambient temperatures between +10 °C and +50 °C.

Special and tried and true

The „specialist“ among the Orbital Rotators for every-day use. Use of this robustly designed unit is easy and its uses are multifarious, for example when soil samples must be exactly settled, mixed and processed. The unit is maintenance-free, carries the GS safety approval and comes with the CE mark.

Technical Data

Overall dimensions (W x D x H):

770 x 700 x 715 mm

Load: max. 20 kg

with uniform load distribution

Motion: orbital rotating

Capacity: max. 12 bottles / vessels

Bottle/vessel dimensions:

max. 110 mm diameter, round or square / rectangular, max. 270 mm height

Shaking frequency: 1 - 20 rpm

Electrical connection:

230 V* 50...60 Hz, 100 W

* Other voltages on request!

Net/gross weight: 62/78 kg

Packing volume (cardboard box): 0.91 m³

Order No. 3040



Features

- ▶ compact, low-wear drive mechanism
- ▶ housing made of electrolytically galvanised, powder-coated sheet steel
- ▶ a d.c. motor with overload protection drives the unit
- ▶ electronic speed control, stepless
- ▶ constant speed during continuous operation
- ▶ clearly laid out control panel for easy operation: main switch with control lamp, rotary selector switch for setting and LED display for speed indication and lever for the stopping device of the rotating rack, which guarantees easy clamping of the sample vessels

- ▶ rotating rack with ball bearings on both sides, able to accommodate a max. of 12 flasks/vessels, round or square/rectangular, up to a diameter of 110 mm and a height of 270 mm, in four planes, each plane with three holding frames. Drive is implemented via a toothed belt and a sliding hub.
- ▶ holding frame for safe, secure clamping of the sample vessels, made of stainless steel

Applications

The uniform rotating motion of this special Shaker make it particularly well-suited for processing soil samples in glass/plastic wide-mouth vessels with up to 2000 ml rated volume as per DIN 38414, Part 4 „German Standard Methods for Water, Wastewater and Sludge Analysis - Determination of Leachability by Water“ .

This unit can be used in ambient temperatures between +10 °C and +40 °C.

Accessories



3005



3006



Shaking tray

made of stainless steel, 330 x 330 mm, with holes to accommodate clamps for Erlenmeyer flasks and other accessory equipment

Order No. 3950



Clamps

made of stainless steel for Erlenmeyer flasks, for screwing on to shaking tray 3950, complete with attachment materials

- Order No. 3983 for 25 ml flasks (45*)
- Order No. 3984 for 50 ml flasks (25*)
- Order No. 3985 for 100 ml flasks (16*)
- Order No. 3986 for 200 ml flasks (12*)
- Order No. 3987 for 250-300 ml flasks (9*)
- Order No. 3988 for 500 ml flasks (9*)
- Order No. 3989 for 1000 ml flasks (4*)
- Order No. 3990 for 2000 ml flasks (2*)

Other clamps on request

* max. number of clamps per shaking tray



Test tube rack

made of stainless steel, for test tubes; perforated section can be tilted by 90°, with clamping springs for secure grip and silent shaking of glasses; can be screwed on to shaking tray 3950

Order No. 3953

for a max. of 24 tubes: 12 - 17 mm diameter
Capacity of tray: three test tube racks



Clamps

made of stainless steel, for separating funnels, for screwing on to shaking tray 3950

Order No. 3957 for 50 ml separating funnels (6*)
(ISO/Squibb, neck 19/26)

Order No. 3958 for 100 ml separating funnels (6*)
(ISO/Squibb, neck 19/26)

Order No. 3959 for 250 ml separating funnels (4*)
(ISO/Squibb, neck 19/26)

Order No. 3955 for 250 ml separating funnels (4*)
(conical form, neck 29/32)

Order No. 3956 for 500 ml separating funnels (3*)
(ISO/Squibb, neck 29/32)

Other clamps on request

* Max. number of clamps per shaking tray

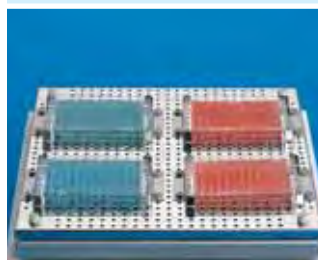

Holding frame

made of stainless steel, for attachment of a test plate, for screwing on to shaking tray 3950, complete with attachment materials

Order No. 3910

Capacity of tray: four test plates



Non-slip mat

for the shaking platform, 300 x 300 mm size, for slow moving, e.g. nutrient solutions in Petri dishes and flasks

Order No. 3951



Universal mount

for secure attachment of different shaking objects between the four rubber-coated bars

Order No. 3952

Accessories



3011



3012



3013



3014



Shaking tray
made of stainless steel,
450 x 450 mm, with holes to
accommodate clamps for
Erlenmeyer flasks and other
accessory equipment

Order No. 3966



Clamps
made of stainless steel for
Erlenmeyer flasks, for screwing
on to shaking tray 3966,
complete with attachment
materials

- Order No. 3983 for 25 ml flasks (79*)
- Order No. 3984 for 50 ml flasks (49*)
- Order No. 3985 for 100 ml flasks (36*)
- Order No. 3986 for 200 ml flasks (22*)
- Order No. 3987 for 250-300 ml flasks (16*)
- Order No. 3988 for 500 ml flasks (12*)
- Order No. 3989 for 1000 ml flasks (9*)
- Order No. 3990 for 2000 ml flasks (4*)

Other clamps on request

* Max. number of clamps per shaking tray



Order No. 3965

Non-slip mat
for the shaking platform,
420 x 420 mm size, for slow
moving, e.g. nutrient solutions
in Petri dishes



Order No. 3967

Universal mount
for secure attachment of
different shaking objects
between the six rubber-
coated bars



Order No. 3968

Platform frame
with four levels, with top rims,
three levels removable. Frame
and trays made of stainless steel.
Distance between trays - 60 mm.
Grooved rubber mats on trays to
ensure secure grip of objects.

Accessories



3015



3017



3016



3018

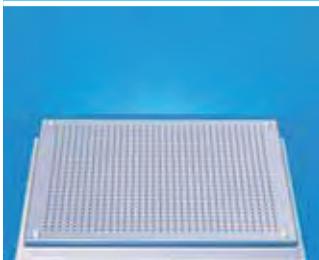

Shaking tray

made of stainless steel, 450 x 450 mm, with holes to accommodate clamps for Erlenmeyer flasks and other accessory equipment

Order No. 3966



Clamps

made of stainless steel for Erlenmeyer flasks, for screwing on to shaking tray 3966, complete with attachment materials

- Order No. 3983** for 25 ml flasks (79*)
- Order No. 3984** for 50 ml flasks (49*)
- Order No. 3985** for 100 ml flasks (36*)
- Order No. 3986** for 200 ml flasks (22*)
- Order No. 3987** for 250-300 ml flasks (16*)
- Order No. 3988** for 500 ml flasks (12*)
- Order No. 3989** for 1000 ml flasks (9*)
- Order No. 3990** for 2000 ml flasks (4*)

Other clamps on request

* Max. number of clamps per shaking tray

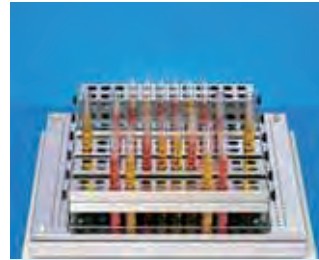

Test tube rack

made of stainless steel, for test tubes; perforated section can be tilted by 90°, with clamping springs for secure grip and silent shaking of glasses; can be screwed on to shaking tray 3966

Order No. 3953

for a max. of 24 tubes: 12 - 17 mm diameter
capacity of tray: six test tube racks



Clamps

made of stainless steel, for separating funnels, for screwing on to shaking tray 3966

Order No. 3957 for 50 ml separating funnels (11*)
(ISO/Squibb, neck 19/26)

Order No. 3958 for 100 ml separating funnels (11*)
(ISO/Squibb, neck 19/26)

Order No. 3959 for 250 ml separating funnels (8*)
(ISO/Squibb, neck 19/26)

Order No. 3955 for 250 ml separating funnels (8*)
(conical form, neck 29/32)

Order No. 3956 for 500 ml separating funnels (6*)
(ISO/Squibb, neck 29/32)

Other clamps on request

* Max. number of clamps per shaking tray

Holding Frame

made of stainless steel, for attachment of a test plate, for screwing on to shaking tray 3966, complete with attachment materials

pict. see Shakers 3019 - 3020

Order No. 3910

Capacity of tray: six test plates



Non-slip mat

for the shaking platform, 420 x 420 mm size, for slow moving, e.g. nutrient solutions in Petri dishes

Order No. 3965



Universal mount

for secure attachment of different shaking objects between the six rubber-coated bars

Order No. 3967

Accessories



3019



3020



Order No. 3980

Shaking tray

made of 3-mm-thick anodised aluminium, 670 x 537 mm, with holes to accommodate clamps for Erlenmeyer flasks and other accessory equipment



Clamps

made of stainless steel for Erlenmeyer flasks, for screwing on to shaking tray 3980, complete with attachment materials

- Order No. 3983** for 25 ml flasks (99*)
- Order No. 3984** for 50 ml flasks (99*)
- Order No. 3985** for 100 ml flasks (50*)
- Order No. 3986** for 200 ml flasks (26*)
- Order No. 3987** for 250-300 ml flasks (26*)
- Order No. 3988** for 500 ml flasks (26*)
- Order No. 3989** for 1000 ml flasks (12*)
- Order No. 3990** for 2000 ml flasks (9*)

Other clamps on request

* Max. number of clamps per shaking tray

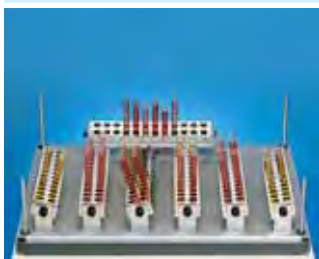

Order No. 3953

for a max. of 24 tubes: 12 - 17 mm diameter
Capacity of tray: nine test tube racks

Test tube rack

made of stainless steel for test tubes; perforated section can be tilted by 90°, with clamping springs for secure grip and silent shaking of glasses; can be screwed on to shaking tray 3980



Order No. 3910

Capacity of tray: fifteen test plates

Holding frame

made of stainless steel, for attachment of a test plate, for screwing on to shaking tray 3980, complete with attachment materials



Order No. 3982

Universal mount

for secure attachment of shaking objects. The mount consists of two longitudinal bars and six transverse bars. Screw-type clamps are used for adjusting the longitudinal bars vertically and transverse bars horizontally.



Order No. 3981

Rack frame

for doubling the capacity by accommodating two shaking trays 3980; distance between trays - 205 mm. The bottom tray can be loaded with flasks up to a max. of 500 ml.

Summary of Laboratory Products



■ Chest Freezers Page 3



■ Upright Freezers Page 3

■ Water Baths Page 21



■ Tissue Float Bath Page 31



■ Shaking Water Baths Page 33

■ THERMOLAB® Page 38

■ Incubators Page 41

■ Shaking Incubators Page 44



■ Hybridisation Incubator Page 48

■ Mini Incubator Page 50

■ Tube Roller Incubator Page 50



■ Shakers Page 53

■ Test Tube Rotator Page 64

■ Rotating Shaker Page 65



■ Water Stills Page 71



Would you like to find out more details about our range of products?

Phone: ++ 49 - 5139 99 58 - 0

Fax: ++ 49 - 5139 99 58 21

E-Mail: info@GFL.de

Internet: www.GFL.de

Water Stills

GFL®



■ The result of decades of experience and technical innovation: four individually applicable product ranges with 14 different models.



Quality built on Tradition

Users in research labs, standard and special labs for medicine, science and industry throughout the world have been profiting from the precision and dependability of our products for 45 years, all of which comply with valid European standards and bear the CE mark.

In the future, the success of a product spectrum of laboratory devices that meet the toughest demands on material, functioning and design will continue to be ensured by experience of every-day use in detail, ongoing technical advances and an excellent quality approach.

The phrase „Quality built on Tradition“ encompasses more than just the sum of impressive product innovations. It is also an expression of our corporate policy, which includes a high degree of ready-and-waiting service as our primary customer-friendly service goal.

This applies to all of the GFL laboratory products that are produced exclusively at our plant in Germany - Deep Freezers, Shakers, Shaking Water Baths, Water Baths, Incubators or Water Stills alike.



Secure future

A vested quality demand in accordance with international standards is documented for all GFL laboratory products with the certification to DIN EN ISO 9001:2008, promoting more trust in the permanent high quality level of our products.

In addition to the continuous optimisation of ongoing production processes, the ISO obligation also calls for the commitment to quality awareness of our employees and the continuous development and rapid implementation of preventive measures to ensure quality assurance at a high level.

Strong partners on a high level



Decades of experience and technical innovation have set the standards: GFL Water Stills produce ultra-pure, low-gas, bacteria and pyrogen free distillate with a very low conductivity. It is in conformity with DAB requirements and international pharmacopoeia regulations.

The conductivities for each model stated in this brochure are average values, determined by Institute

Fresenius, for use with tap water, and are to be understood as approximate values. Depending on the quality of tap water, the conductivity obtained might easily be improved.

All over the world, four highly efficient GFL Water Still ranges are offered, comprising 14 different models with capacities of 2 – 12 litres per hour. The distillate is used in research and development, for instance in bacteriological and medical preparation of samples and for the preparation of cell and tissue cultures. It is also used for cleaning and sterilisation processes,

for buffer solutions and for microbiological and analytical applications, especially for HPLC.

By distilling the heated cooling water, all units operate highly economically. They are reliable, maintenance-free, user and service friendly and have the CE mark.

Accessories shown in this brochure are not part of the standard scope of supply of the units. The right of constructional modifications remains reserved. Special makes are available.

Contents

Product No.		Page	Accessories / Page
2001/2 and 2001/4	Mono Water Stills without storage tank for bench mounting	75	82 / 84
2002	Mono Water Still with storage tank for bench and wall mounting	76 / 77	82 / 84
2004	Mono Water Still with storage tank for bench and wall mounting	76 / 77	82 / 85
2008 to 2012	Mono Water Stills with storage tank for bench and wall mounting	76 / 77	82 / 86
2102 to 2108	Double Distillers for bench and wall mounting	78 / 79	82 / 86
2202 to 2304	Glass Mono and Bi Distillers for bench and wall mounting	80 / 81	82 / 87

Water. The Origin of All life

- Water is the origin of all life, an indispensable and irreplaceable natural product for man, beast and plant. Not only is water our most important food, it also possesses the highest solubility of all known substances, a discovery that led to the production of pure water through distillation (lat. *destillare* / drip down) probably as early as 5,000 years ago.

Pure water. On the art of distillation.

Distillation is the most effective and reliable way of producing pure water, the exceptional quality being that the only additive required is energy. Compared to other additives, such as e.g. adsorbents or solvents, energy can easily be added to and extracted from a system. Furthermore, Water Stills require very little maintenance. Apart from regular cleaning intervals they are completely maintenance-free.

The distillation process means the phase transformation of liquids (raw water: spring water, tap water or pretreated water) into steam and back to liquids. The transformation of liquids to steam separates effectively water from impurities having a higher boiling point than water. They remain as sediments in the condenser chamber (evaporator). The steam and some very few substances that have a lower or the same boiling point as water are brought to condensation.

Steam condensation produces distilled water, also called Aquadest (lat. *aqua destillata*). This "pure water" has a purity degree of approx. 99.5% regarding salts, organic substances, micro-organisms, pyrogens and bacteria. The pH value of the produced distillate turns slightly acidic when carbon dioxide from the environmental air dissolves in the distillate. Carbon dioxide is absorbed until a dynamic balance between water and environmental air develops. Pure water should, therefore, be used up quickly or stored under airtight conditions.

The conductivity of distillate mainly depends on the quality of raw water and the construction of the Water Still. By connecting a second distillation stage (bi distillation), respectively by using special materials in the Water Still (glass) the purity of the distillate can be further increased.



Alambic with water cooling around the distillation helmet.

In the developmental history of distillation equipment, this unconventional model disposes of a cooling basin shaped like an oriental turban.

2001/2 - 2001/4



Specifications and Features

- ▶ good distillate quality, conductivity approx. 2.3 $\mu\text{s} / \text{cm}$ at 25 °C
- ▶ for drainage and cleaning, evaporator is easily accessible by lifting the condenser. Material: stainless steel, material no. 1.4301
- ▶ condenser (cooler) with baffle. Material: stainless steel, material no. 1.4301
- ▶ heating element made of stainless steel, material no. 1.4876
- ▶ thermostatic low water cut-off, to protect the heating element in case of low water
- ▶ thermometer to display the temperature of the cooling water
- ▶ energy-saving through distillation of the heated cooling water
- ▶ distillate withdrawal through drain tube on the front of the unit
- ▶ cooling water inlet and outlet on the right-hand side of the unit *
- ▶ water connection: cooling water inlet 1/2 inch (inner \varnothing 12.7 mm), cooling water outlet 1/2 inch (inner \varnothing 12.7 mm) *
- ▶ degassing of carbon dioxide through vent in the condenser
- ▶ main switch with pilot lamp on the front of the unit
- ▶ housing electrostatically powder-coated with epoxy resin
- ▶ power connection through mains connection cable with German shock-proof type (Schuko) plug

Compact and efficient

Product range 2001/2 and 2001/4 comprises two mono water stills without storage tank, for bench mounting, that produce two and four litres of distillate per hour.

Their easy handling makes them an indispensable help in producing high-quality distillate.



2001/4 Mono Water Still 4 l / h, for bench mounting

Technical data

Model Order No.	Capacity l / h	Cooling water requirement l / h approx.	Exterior dimensions mm approx.			Electrical connection*	Weight kg approx.		Packing volume approx. m ³
			Width	Depth	Height		net	gross cardboard box	
2001/2	2	20	280	250	490	230 V / 50...60 Hz / 2.0 kW	7.5	10	0.10
2001/4	4	40	280	250	490	230 V / 50...60 Hz / 3.0 kW	7.5	10	0.10

* Other voltages available on request

* Tubes for water inlet and outlet can be supplied as accessories.

2002 - 2012

■ Comfortable and reliable

Models 2002 – 2012 with automatic operation supply two, four, eight and twelve litres of distillate per hour, depending on the model type.

The built-in distillate storage tank accepts double the hourly capacity of the Water Still. All models have successfully proved in every-day laboratory routine. They dispose of an electronic monitoring function which ensures a continuous production of distillate.

Specifications and Features

- ▶ good distillate quality, conductivity approx. $2.3 \mu\text{s} / \text{cm}$ at $25 \text{ }^\circ\text{C}$
- ▶ heating element made of stainless steel, material no. 1.4876
- ▶ thermostatic low water cut-off, to protect the heating element in case of low water
- ▶ energy-saving through distillation of the heated cooling water



2004 Mono Water Still 4 l / h with built-in storage tank 8 l, for bench and wall mounting

- ▶ degassing of carbon dioxide through vent in the top
- ▶ evaporator with baffle is easily accessible by lifting the lids. Material: stainless steel, material no. 1.4301
- ▶ storage tank for distillate accepts double the hourly capacity of the unit. Material: stainless steel, material no. 1.4301
- ▶ condenser (cooling coil) in the storage tank, easily exchangeable. Material: stainless steel, material no. 1.4301
- ▶ water supply through a built-in solenoid valve with connection for water pressure hose 1/2 inch (inner Ø 12.7 mm) *
- ▶ cooling water pressure required: > 3 bar to max. 7 bar. After switching on the main switch the solenoid valve opens the water supply and closes it once the storage tank is full, thus avoiding unnecessary waste of water
- ▶ cooling water outlet with hose connection 3/4 inch (inner Ø 19 mm). Water that has not been condensed flows off through the cooling water outlet *
- ▶ distillate withdrawal through the drain cock on the front of the unit. The drain cock can be opened in either continuous or touch position
- ▶ an electronic level switch switches the still off when the storage tank is full and restarts it automatically when distillate is withdrawn
- ▶ an electronic impurity detector switches the unit off in case of high degree impurities in the evaporator, the red pilot lamp "Clean" will glow
- ▶ drainage of the evaporator through drain cock on the right-hand side of the unit
- ▶ main switch and pilot lamps (yellow pilot lamp for operation and red pilot lamp for cleaning) are on the front of the unit
- ▶ double-walled housing. Housing is made of electrolytically galvanized sheet steel, electrostatically powder-coated with epoxy resin
- ▶ power connection through connection cable; 2 and 4 litre units have German shock-proof type (Schuko) plug

Technical data

Model Order No.	Capacity l / h	Storage tank Contents / l	Cooling water requirement l / h approx.	Exterior dimensions mm approx.			Electrical connection*	Weight kg approx.		Packing volume approx. m ³
				Width	Depth	Height		net	gross cardboard box	
2002	2	4	30	540	290	420	230 V / 50...60 Hz / 1.5 kW	15.4	18.5	0.16
2004	4	8	48	620	330	460	230 V / 50...60 Hz / 3.0 kW	20.2	24.0	0.16
2008	8	16	72	780	410	540	400 V / 3ph/N/PE / 50...60 Hz / 6.0 kW three-phase current	30.7	41.0	0.34
2012	12	24	198	780	410	670	400 V / 3ph/N/PE / 50...60 Hz / 9.0 kW three-phase current	43.0	47.0	0.48

* Other voltages available on request

* Tubes for water inlet and outlet can be supplied as accessories.

2102 - 2108

■ Operation and Service Friendly

Double Distillers 2102 – 2108 are produced of a material combination of stainless steel / glass, without storage tank. Operating fully automatic, they produce two, four or eight litres of distillate per hour, depending on the model.



A stop valve made of Duran glass D 50 enables mono distillate to be withdrawn

2104 Double Distiller 4 l / h, for bench and wall mounting

Control panel with clear symbols for easy monitoring of operation



Specifications and Features

- ▶ excellent distillate quality, conductivity of mono-distillate approx. 2.2 $\mu\text{s} / \text{cm}$ at 25 °C; conductivity of bi-distillate approx. 1.6 $\mu\text{s} / \text{cm}$ at 25 °C
- ▶ evaporator and baffle of the mono stage are easily accessible by lifting the condensers. Material: stainless steel, material no. 1.4301
- ▶ condensers (coolers):
1st stage made of stainless steel, material no. 1.4301;
2nd stage including baffle made of DURAN® Borosilicate glass 3.3
- ▶ heating elements made of stainless steel, material no. 1.4876
- ▶ water supply through built-in solenoid valve with connection for water pressure hose 1/2 inch (inner \varnothing 12.7 mm) *
- ▶ required cooling water pressure: > 3 bar to max. 7 bar. After switching on the main switch the solenoid valve opens the water supply
- ▶ cooling water outlet with hose connection 3/4 inch (inner \varnothing 19 mm). Water that has not been condensed flows off through the cooling water outlet *
- ▶ energy-saving through distillation of the heated cooling water
- ▶ distillate withdrawal:
stop valve made of Borosilicate glass 3.3 with PTFE plunger for mono distillate, outlet with dust guard shield made of Borosilicate glass 3.3 for bi-distillate
- ▶ low water cut-off: float switch and thermostatic over-temperature cut-out
- ▶ an electronic impurity detector switches the unit off in case of high degree impurities in the 1st stage evaporator, the red pilot lamp "Clean" will glow
- ▶ degassing of carbon dioxide through vent on the condensers
- ▶ main switch and pilot lamps to monitor both distillation stages are on the front of the unit
- ▶ two-part housing made of electrolytically galvanized sheet steel, electrostatically powder-coated with epoxy resin; upper part easily removable through quick-release catches
- ▶ power connection through connection cable

Technical data

Model Order No.	Capacity l / h	Cooling water requirement l / h approx.	Exterior dimensions mm approx.			Electrical connection*	Weight kg approx.		Packing volume approx. m ³
			Width	Depth	Height		net	gross cardboard box	
2102	2	72	500	260	470	230 V / 50...60 Hz / 3.5 kW	18	26	0.26
2104	4	120	550	280	570	400 V / 3ph/N/PE / 50...60 Hz / 6.5 kW three-phase current	23	35	0.34
2108	8	198	700	390	700	400 V / 3ph/N/PE / 50...60 Hz / 11.5 kW three-phase current	39	55	0.62

* Other voltages available on request

* Tubes for water inlet and outlet can be supplied as accessories.

2202 - 2304

Excellent Quality and Technology

Due to their extremely low content of metal ions in the distillate our Glass Water Still count among the top-end products in the market. GFL produces a range of five fully automatic models.

Three models produce mono distillate of two, four and eight litres / hour. For bi-distillation, we offer two models with capacities of two and four litres per hour.

Specifications and Features

- ▶ excellent distillate quality, conductivity of mono distillate approx. 2.2 µs / cm at 25 °C; conductivity of bi-distillate approx. 1.6 µs / cm at 25 °C
- ▶ evaporators, condensers and overflows made of DURAN® / Borosilicate glass 3.3. Condensers with dribble guard
- ▶ water supply through built-in solenoid valve with connection for water pressure hose 1/2 inch (inner Ø 12.7 mm)*
- ▶ required cooling water pressure: > 3 bar to max. 7 bar. After switching on the main switch the solenoid valve opens the water supply
- ▶ cooling water outlet with hose connection 1/2 inch (inner Ø 12.7 mm).
- ▶ Water that has not been condensed flows off through the cooling water outlet*
- ▶ energy-saving through distillation of the heated cooling water
- ▶ heating element with quartz sheathing
- ▶ sterilisation of the condensers by steam
- ▶ electronic level control during the whole distillation process
- ▶ water level control in the condenser with automatic power cut-off in case of water shortage
- ▶ electronic impurity detector induces automatic water change to rinse and clean the evaporator
- ▶ degassing of carbon dioxide through a vent on the condenser
- ▶ main and function switches as well as pilot lamps for monitoring are on the front of the unit
- ▶ distillate withdrawal at the right-hand side of the unit through hose connection*
- ▶ visible distillation process through easily removable, unbreakable front screen that does not steam up
- ▶ housing made of electrolytically galvanized sheet steel, electrostatically powder-coated with epoxy resin
- ▶ power connection through connection cable (models 2202, 2204 and 2302 with German shock-proof Schuko plug)

Technical data

Model Order No.	Capacity l / h	Cooling water requirement l / h approx.	Exterior dimensions mm approx.			Electrical connection*	Weight kg approx.		Packing volume approx. m ³
			Width	Depth	Height		net	gross cardboard box	
2202 Mono	2	48	650	200	390	230 V / 50...60 Hz / 1.5 kW	16	22.0	0.34
2204 Mono	4	96	650	200	390	230 V / 50...60 Hz / 3.0 kW	17	22.0	0.34
2208 Mono	8	144	650	365	390	400 V / 3ph/N/PE / 50...60 Hz / 6.0 kW three-phase current	24	30.0	0.34
2302 Bi	2	96	650	365	390	230 V / 50...60 Hz / 2.9 kW	24	30.5	0.34
2304 Bi	4	144	650	365	390	400 V / 3ph/N/PE / 50...60 Hz / 5.8 kW three-phase current	24	31.5	0.34

* Other voltages available on request

* Tubes for water inlet and outlet can be supplied as accessories.

The fully automatic functions "Clean" and "Sterilising" can be induced manually on the control panel



2304 Glass Bi-Distiller 4 l / h,
for bench and wall mounting



2202 Glass Mono Distiller 2 l / h,
for bench and wall mounting

Accessories / Pretreatment

Pretreatment for all GFL Water Stills 2001/2 - 2001/4, 2002 - 2012, 2102 - 2108, 2202 - 2304



Order No. 2904

Dechlorite Filter

eliminates chlorine particles in the tap water added by the local water works. Complete with connections for pressure hose 1/2 inch * (inner Ø 12.7 mm), including first filling. The filling should be exchanged every six months.

* Tubes for water inlet and outlet are not included in the standard scope of supply

Spare Filling

for Dechlorite Filter

Order No. 2905



Order No. 2906

Phosphate Cartridge

prevents scale formation in the condenser by phosphatising the tap water. Can be used from 4-15°dH (German hardness). Complete with connections for pressure hose 1/2 inch * (inner Ø 12.7 mm), including first filling. The filling should be replaced according to the consumption.

* Tubes for water inlet and outlet are not included in the standard scope of supply

Spare Filling

for Phosphate Cartridge

Order No. 2907



Order No. 2912

Pre-Filter 1 µm

for pre-cleaning the tap water, and to protect the unit from premature contamination. Food safe according to FDA regulations. Complete with connections for pressure hose 1/2 inch * (inner Ø 12.7 mm), including filter candle. The candle should be replaced every six months.

* Tubes for water inlet and outlet are not included in the standard scope of supply

Spare Candle

for Pre-Filter

Order No. 2913

Accessories for Order Nos. 2904, 2906, 2912



Order No. 2921

Wall Bracket

for one filter, with screws to fix the filter to the wall bracket



Order No. 2922

Wall Bracket

for two filters, with one sleeve to connect the filters and screws to fix the filters to the wall bracket



Order No. 2923

Wall Bracket

for three filters, with two sleeves to connect the filters and screws to fix the filters to the wall bracket

Connection Variants for Pre-Filter, Dechlorite Filter and Phosphate Cartridge

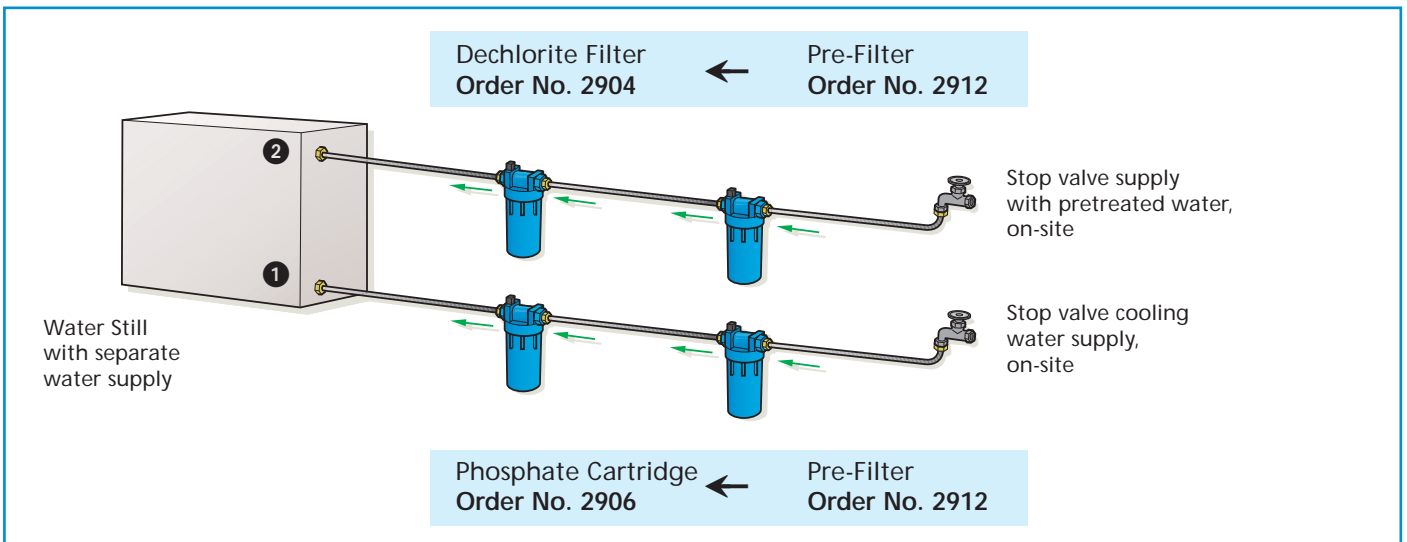
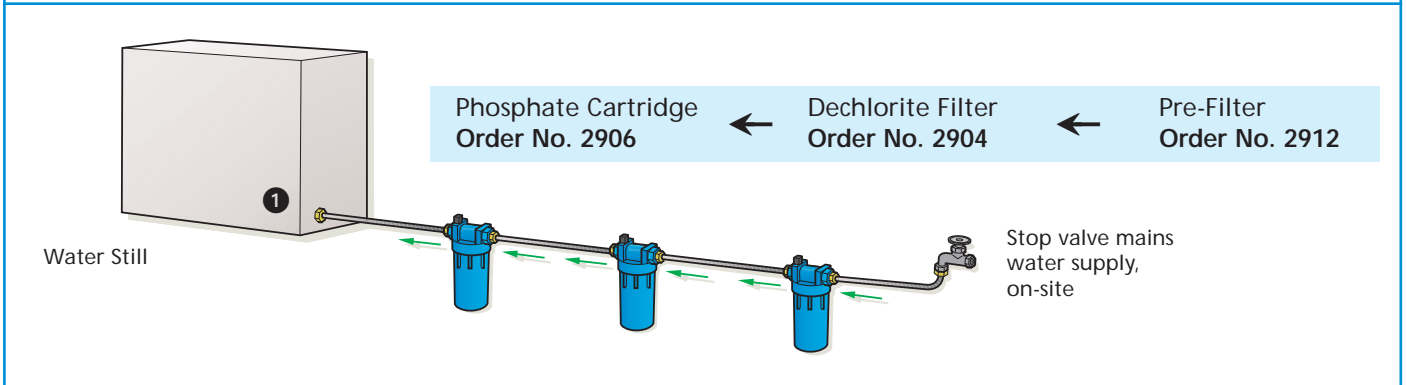
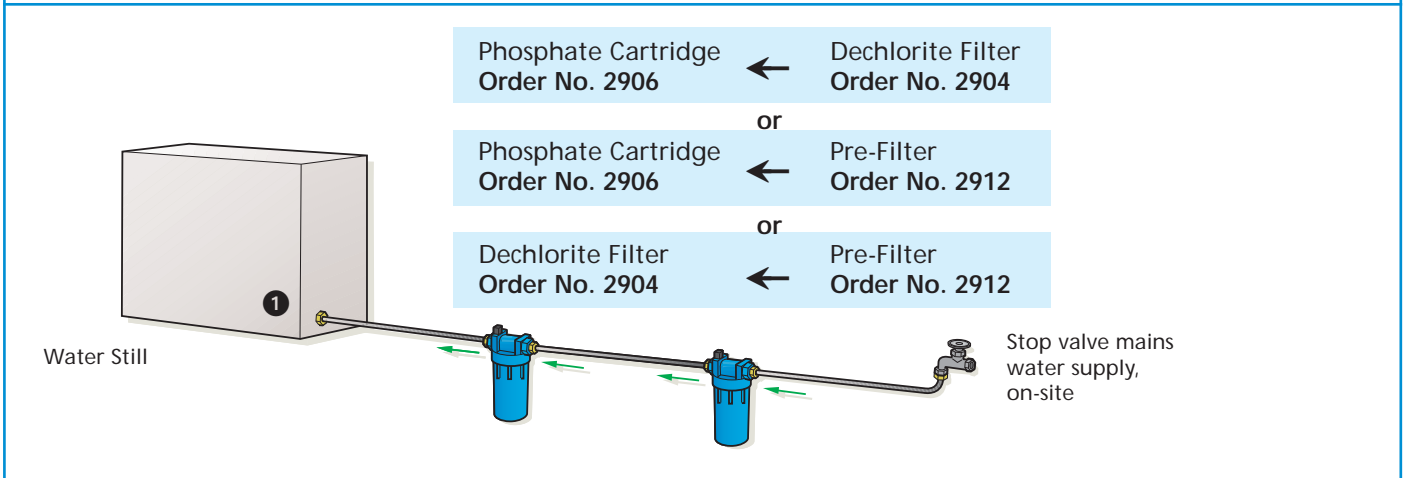
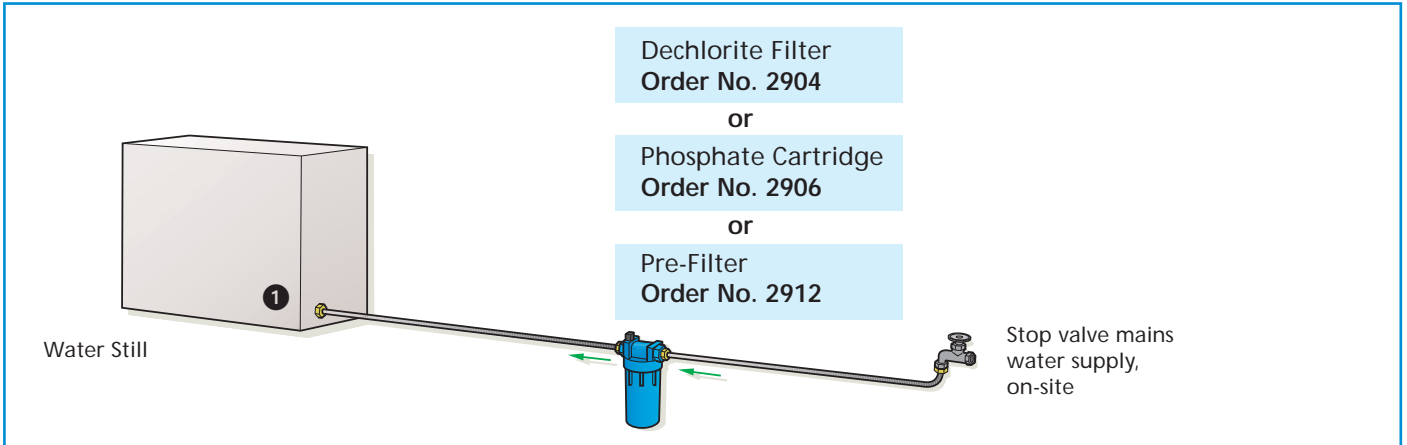

1 Tap water supply 2 Inlet separate water supply The connection sequence must by all means be observed

Accessories



2001/2 - 2001/4



Hose Set

consisting of hoses for water inlet and outlet (1.5 m) and hose clips

Order No. 2940



2002

Separate Water Supply

to feed the evaporator with softened or desalinated water (pressure > 1 bar) and the cooling coil (pressure > 3 bar) with phosphate-treated or normal tap water.

Efficiency of the still is reduced by approx. 10 – 15 %

Order No. 2901



Hose Set

consisting of hoses for water inlet and outlet (1.5 m) and hose clips

Order No. 2941



Hose Set

consisting of hoses for water inlet and outlet (1.5 m) and hose clips, in connection with Separate Water Supply 2901

Order No. 2946



2004

Separate Water Supply

to feed the evaporator with softened or desalinated water (pressure > 1 bar) and the cooling coil (pressure > 3 bar) with phosphate-treated or normal tap water.

Efficiency of the still is reduced by approx. 10 – 15 %

Order No. 2901

Separate Water Supply with Solenoid Valve

to feed the evaporator with softened or desalinated water (pressure > 1 bar) and the cooling coil (pressure > 3 bar) with phosphate-treated or normal tap water. **The solenoid valve switches the pretreated water off when the storage tank is full.**

Efficiency of the still is reduced by approx. 10 – 15 %

Order No. 2909



Level Control Switch for an External Storage Tank

to switch off power and water when the external storage tank is full (not included in the standard scope of supply)

Order No. 2910



Hose Set

consisting of hoses for water inlet and outlet (1.5 m) and hose clips

Order No. 2941



Hose Set

consisting of hoses for water inlet and outlet (1.5 m) and hose clips, in connection with Separate Water Supply 2901 or 2909

Order No. 2946

Accessories



2008 - 2012

Separate Water Supply

to feed the evaporator with softened or desalinated water (pressure > 1 bar) and the cooling coil (pressure > 3 bar) with phosphate-treated or normal tap water.

Efficiency of the still is reduced by approx. 10 – 15 %

Order No. 2901

Separate Water Supply with Solenoid Valve

to feed the evaporator with softened or desalinated water (pressure > 1 bar) and the cooling coil (pressure > 3 bar) with phosphate-treated or normal tap water. **The solenoid valve switches the pretreated water off when the storage tank is full.**

Efficiency of the still is reduced by approx. 10 – 15 %

Order No. 2909



Level Control Switch for an External Storage Tank

to switch off power and water when the external storage tank is full (not included in the standard scope of supply)

Order No. 2910

Heating with Thermostat for the Internal Storage Tank

to maintain sterility of the distillate

Order No. 2911



Hose Set

consisting of hoses for water inlet and outlet (1.5 m) and hose clips

Order No. 2941



Hose Set

consisting of hoses for water inlet and outlet (1.5 m) and hose clips, in connection with Separate Water Supply 2901 or 2909

Order No. 2946



2102 - 2108

Separate Water Supply with Solenoid Valve

to feed the evaporator with softened or desalinated water (pressure > 1 bar) and the cooling coil (pressure > 3 bar) with phosphate-treated or normal tap water. Both cooling and pretreated water feed are automatically controlled by the unit.

Efficiency of the still is reduced by approx. 10 – 15 %

Order No. 2903

Level Control Switch for an External Storage Tank

to switch off power and water when the external storage tank is full (not included in the standard scope of supply)

pict. see 2008 - 2012

Order No. 2910



Hose Set

consisting of hoses for water inlet and outlet (1.5 m) and hose clips

Order No. 2941



Hose Set

consisting of hoses for water inlet and outlet (1.5 m) and hose clips, in connection with Separate Water Supply 2903

Order No. 2947



2202 - 2208

Separate Water Supply with Solenoid Valve

to feed the evaporator with softened or desalinated water (pressure > 1 bar) and the cooling coil (pressure > 3 bar) with phosphate-treated or normal tap water. Both cooling and pretreated water feed are automatically controlled by the unit.

Efficiency of the still is reduced by approx. 10 – 15 %

Order No. 2902



2302 - 2304

Separate Water Supply with Solenoid Valve

to feed the evaporator with softened or desalinated water (pressure > 1 bar) and the cooling coil (pressure > 3 bar) with phosphate-treated or normal tap water. Both cooling and pretreated water feed are automatically controlled by the unit.

Efficiency of the still is reduced by approx. 10 – 15 %

Order No. 2902



Level Control Switch for an External Storage Tank

to switch off power and water when the external storage tank is full (not included in the standard scope of supply)

Order No. 2908



Level Control Switch for an External Storage Tank

to switch off power and water when the external storage tank is full (not included in the standard scope of supply)

Order No. 2908



Hose Set

consisting of hoses for water inlet and outlet (1.5 / 1.0 m), distillate withdrawal (0.5 m) and hose clips

Order No. 2943



Hose Set

consisting of hoses for water inlet and outlet (1.5 / 1.0 m), distillate withdrawal (0.5 m) and hose clips

Order No. 2944



Hose Set

consisting of hoses for water inlet and outlet (1.5 / 1.0 m), distillate withdrawal (0.5 m) and hose clips, in connection with Separate Water Supply 2902

Order No. 2948



Hose Set

consisting of hoses for water inlet and outlet (1.5 / 1.0 m), distillate withdrawal (0.5 m) and hose clips, in connection with Separate Water Supply 2902

Order No. 2949



GFL Gesellschaft für Labortechnik mbH

P.O. Box 11 52 · 30927 Burgwedel / Germany
Schulze-Delitzsch-Strasse 4 · 30938 Burgwedel / Germany
Phone ++ 49 (0)5139 99 58 -0 · Fax ++ 49 (0)5139 99 58 21
E-Mail: info@GFL.de · Internet: www.GFL.de